

Without Lid

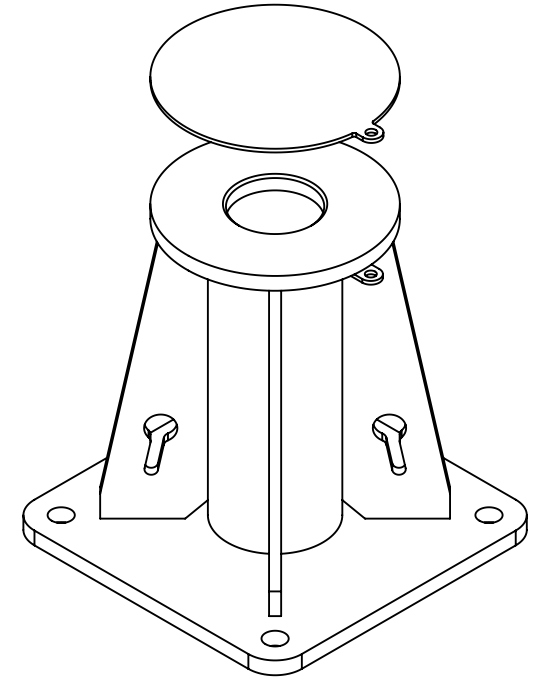

With Lid

DO NOT SCALE DRAWING

REVISION **02**

	NAME	DATE	FINISH:
DRAWN	BJ	15/09/2020	Hot Dip Galvanise
CHK'D			MATERIAL:
APPV'D	CM	26/10/2021	Galvanised Steel

ALL COPYRIGHT AND DESIGN RIGHT SUBSISTING IN THIS DOCUMENT IS THE PROPERTY OF REID LIFTING LIMITED AND MAY NOT BE REPRODUCED WITHOUT REID LIFTING'S CONSENT. THIS DOCUMENT AND THE INFORMATION CONTAINED WITHIN IT IS CONFIDENTIAL AND MAY NOT BE DISCLOSED TO ANY THIRD PARTY NOR USED FOR ANY UNAUTHORISED PURPOSE WITHOUT REID LIFTING'S CONSENT

UNLESS OTHERWISE SPECIFIED:  
DIMENSIONS ARE IN MILLIMETERS



TITLE: **General Arrangement of  
Reid Lifting Top Mount  
Socket Galvanised Steel**

DWG NO. **STMG0500V2** A4

Estimated Weight: 13 kg

1:5

SHEET 1 OF 2

**General Specification**

- Maximum moment 12kN.m (for WLL please refer to specific REID Davit Technical Datasheet)
- For Anchor Forces please refer to specific REID Davit Technical Datasheet
- Weight - 13kg
- For further details and installation information refer to Operations and Maintenance Manual for All REID Davit Products. (available at [www.reidlifting.com](http://www.reidlifting.com))

**Fall Protection Standards**

- Certified as part of an anchor device when use with REID portable Davits to EN795:2012
- Witness tested and conforms to BS8610:2017 when use with TDRA versions. Application Types A1, A2, A3, A4, A5, & A7
- Witness tested and conforms to IRATA ICOP - 15kN minimum break load

**Materials & Finishes**

- Material - Galvanised Steel.

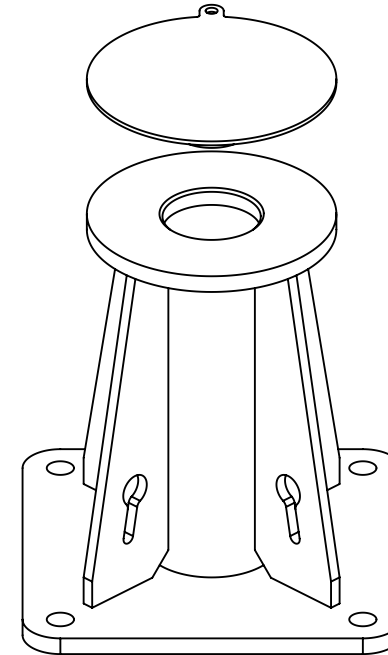

Approved

DO NOT SCALE DRAWING

REVISION

**02**

	NAME	DATE	FINISH:
DRAWN	BJ	15/09/2020	Hot Dip Galvanise
CHK'D			MATERIAL:
APPV'D	CM	26/10/2021	Galvanised Steel

ALL COPYRIGHT AND DESIGN RIGHT SUBSISTING IN THIS DOCUMENT IS THE PROPERTY OF REID LIFTING LIMITED AND MAY NOT BE REPRODUCED WITHOUT REID LIFTING'S CONSENT. THIS DOCUMENT AND THE INFORMATION CONTAINED WITHIN IT IS CONFIDENTIAL AND MAY NOT BE DISCLOSED TO ANY THIRD PARTY NOR USED FOR ANY UNAUTHORISED PURPOSE WITHOUT REID LIFTING'S CONSENT

UNLESS OTHERWISE SPECIFIED:  
DIMENSIONS ARE IN MILLIMETERS



TITLE:

**General Arrangement of  
Reid Lifting Top Mount  
Socket Galvanised Steel**

DWG NO.

**STMG0500V2**

A4

Estimated Weight: 13kg

1:5

SHEET 2 OF 2