



**EURO  
ACCESSORIES**



# TECHNICAL MANUAL PIN ANCHOR SYSTEM

# Pin Anchor Systems

## Contents

Page 1	Introduction and Advantages of Pin Anchors
Page 2	Overview of the Pin Anchor System
Page 3	Embedment Details
Page 4	Selecting the Correct Pin Anchors
Page 5	Calculating the Pin Anchor Load Capacity
Page 6	Angle of Lift
Page 7	Calculating The Load Per Anchor
Page 8	Optimum Pull Out Values for Various Anchors in Relation to Concrete Strength
Page 9	Optimum Pull Out Values for Various Embedment Depths in Relation to Concrete Strength
Page 10	Edge Distances Affecting Pull Out Values
Page 11	Adjacent Anchors Affecting Pull Out Values
Page 12	Examples for Determining Reduction Factors
Page 13	Reductions in Pull Out Values for Narrow Panels
Page 14	Summary
Page 16	Lifting Pipe Units
Page 17	Pin Anchors
Page 19	Pipe Pin Anchors
Page 20	Plate Pin Anchors
Page 21	Eye Anchors
Page 22	Rod Anchors
Page 23	Curved Anchor Pins
Page 27	Pin Anchor Ring Clutches & Combination Ring Clutches
Page 28	Accessories
Page 29	Easy Lift Utility Anchors



### Introduction

The Pin Anchor System has been used successfully worldwide by companies to handle precast concrete units of various weights and dimensions for over 30 years. This manual has been produced to allow the engineer to calculate specific Pin Anchor requirements.

### Advantages

The Pin Anchor System has a “no fuss” engage and release mechanism on the Pin Anchor Lifting Ring Clutch, allowing precast concrete units to be handled economically and quickly, especially when repeated operations are required. The unique gravity action of the system prevents any possibility of accidental release of the concrete unit, whilst also giving a clear visual indication of correct engagement. The Pin Anchor System avoids the need to utilise threaded lifting systems with wire ropes and the relative precautions associated with them. The lack of easily wearing parts and the simplicity of the Lifting Ring Clutch means that they will see many years use, with only basic care.

All lifting components within the Pin Anchor System undergo specific testing procedures. Every Pin Anchor Ring Clutch is individually tested and comes uniquely stamped with a corresponding lifting certificate.

There are six simple steps to utilise the Pin Anchor System:

1. Select the correct capacity and length of Pin Anchor.
2. Insert the Pin Anchor into a corresponding Recess Former, these are re-useable and with adequate cleaning and care should see many repeat uses.
3. Once the Pin Anchor is firmly in place the concrete can be poured.
4. After sufficient concrete strength has been achieved the Recess Former can be removed from the concrete, revealing the head of the Pin Anchor with its safe working load clearly indicated. The Recess Former leaves the anchor below the concrete surface in a hemispherical pocket of a size specific to the corresponding Pin Anchor Ring Clutch.
5. Engage the Pin Anchor Ring Clutch with the Pin Anchor and rotate the head approximately 90 degrees until the foot lies flat on the concrete surface to indicate correct engagement, the base should be orientated to point in the direction of the lifting chains, ie towards the crane hook.
6. Attach lifting chains and commence lifting. The unique spherical nature of the lifting system means that the Ring Clutch will come into correct alignment, and the universal joint of the Lifting Ring Clutch will allow lifting at any angle. Simply reverse section 5 to disengage the Pin Anchor Ring Clutch.

## Overview of the Pin Anchor System

The Pin Anchor system is supplied in a wide range of lifting capacities ranging from 1.3 tonnes to 32.0 tonnes. The method of use is the same throughout the size range. There are three basic components to the range.

### 1. Pin Anchor

The Pin Anchor is permanently cast into the concrete unit. It is manufactured from specially ductile steel, making it safe to use at low temperatures. The round hot forged head of the anchor is clearly stamped with the safe working load in tonnes and is designed to engage with the Pin Anchor Ring Clutch. The base of the Pin Anchor is of a larger diameter to the head but is similarly hot forged. This provides excellent anchorage and load transmittal into the surrounding concrete. This method of transferring loads into the surrounding concrete means that except for minor exceptions, the Pin Anchor system operates without additional reinforcement. This not only reduces costs but reduces set up times. The safe working load of the pins is based on a factor of 3 for safety. See table 2 and figure 1 on the following page for details.

All anchors in the range are regularly batch tested to verify the safety factors applied to them. Every anchor has its batch number clearly stamped on the base, allowing easy access to material analysis reports and batch test results.

### 2. Recess Formers

The Recess Former is manufactured from rubber and is hemispherical in shape. It is designed to open to allow the Pin Anchor to be inserted, once closed it provides an adequate seal to prevent concrete ingress. Once the concrete has been poured and cured the Recess Former is removed to reveal the Pin Anchor in its pocket. The Recess Formers should be oiled and can be used many times over.

In addition there are formers available in narrow widths to ease placement in thin panels. The formers are also offered as a non-articulated item with an alternative method of securing the Pin Anchor in place. These items are detailed on pages 23 and 24.

### 3. Pin Anchor Ring Clutch

The Pin Anchor Ring Clutch is an all cast item specially designed not only to fit the Pin Anchor of its related safe working load but also to match the hemispherical pocket created by the corresponding capacity Recess Former. In this way, one can be assured that no two lifting capacities can be utilised together. Thus guaranteeing the safe working load is matched for all items utilised in the lifting process. The Pin Anchor Ring Clutches are individually tested and come uniquely stamped with a corresponding lifting test certificate. The safe working load of the ring clutch is based on a factor of 3 for safety.



**Embedment Details**

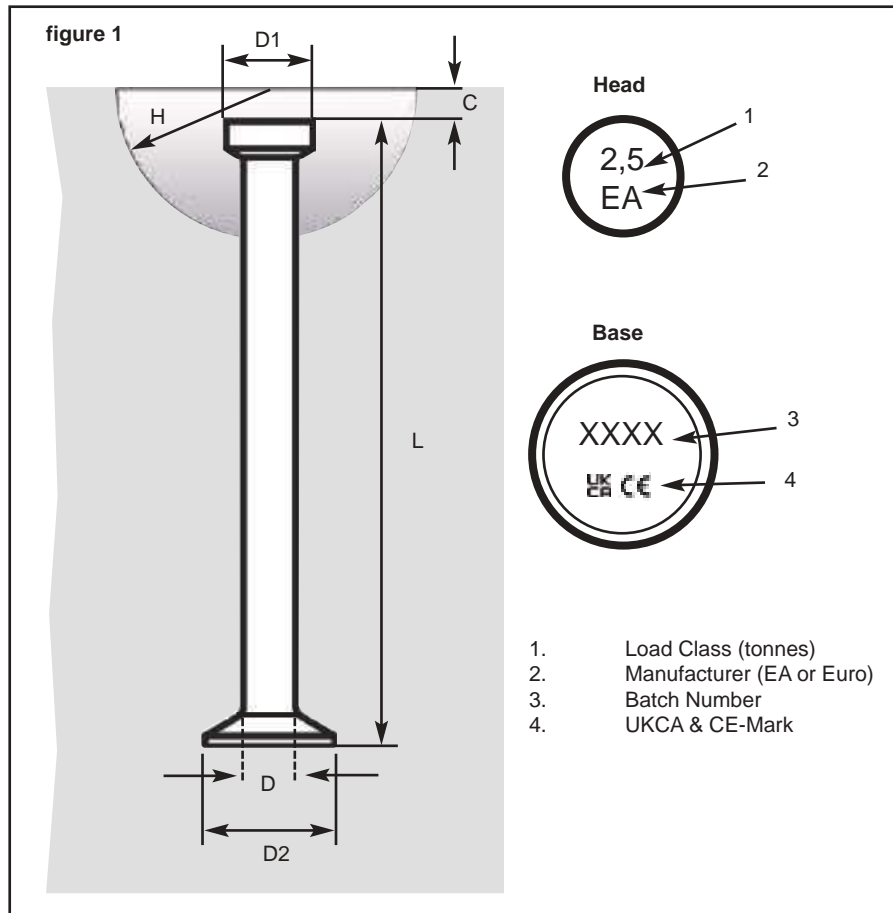

The concrete cover dimension C is applied throughout the Pin Anchor range and applies to anchors detailed on pages 17, 19, 20 and 21. The combination of anchor length L and concrete cover C give anchor embedment E. In addition this combined figure should be considered when determining if adequate concrete cover is being given to the base of the anchor. See figure 1 and table 2.

**table 2**  
Dimensions of Pin Anchors and their Embedment

Load Capacity (tonnes)	D (mm)	D1 (mm)	D2 (mm)	Former Radius H (mm)	Concrete Cover C (mm)	Pin Anchor Length L (mm)
1.3	10	18	25	30	10	35, 40, 50, 55, 65, 85, <b>120</b>
2.5	14	25	35	37	11	45, 55, 65, 70, 85, 100, 120, 140, <b>170</b> , 180, 210, 280
5.0	20	36	50	47	15	65, 75, 80, 85, 95, 100, 110, 120, 140, 150, 160, 170, 180, <b>240</b> , 340
7.5	24	46	60	60	15	85, 95, 100, 120, 140, 150, 160, 165, 200, <b>300</b> , 540
10.0	28	46	70	60	15	85, 100, 110, 115, 120, 135, 150, 170, 200, 220, 250, <b>340</b> , 650, 680
15.0	34	69	85	80	15	140, 150, 165, 200, 210, 300, <b>400</b> , 480
20.0	38	69	98	80	15	165, 200, 250, 340, <b>500</b> , 1000
32.0	50	88	135	108	27	175, 280, 500, <b>700</b> , 1200

Embedment (E) = C + L

Notes: Dimensions in **bold** text are preferred lengths.

### Selecting the Correct Pin Anchor

Selection of the correct Pin Anchor is based upon two main factors. Firstly the safe working load of the Pin Anchor itself and its ability to carry the units in question under all relevant loading conditions at the time of lifting. Such as, weight of unit, de-moulding forces, dynamic loading, the number of effective lifting points and increased tension in angled lifting slings.

Secondly the strength of the surrounding concrete and its ability to resist pull out forces induced upon it by the lifting systems. This can be influenced by several factors. Such as, the compressive strength of the concrete, the Pin Anchor length, edge distances, the distance between adjacent Pin Anchors and the ability of thin panels to resist compressive loads damaging the faces.

This manual will guide you through the necessary steps to determine both of these criteria. Firstly the following should be noted. The normal minimum factor of safety for pull out is 2.5 and tables in this manual are based upon this.

The longest preferred anchor in each load range is designed to give a safety factor of five in concrete of 30 N/mm<sup>2</sup> compressive strength at an ideal edge distance three times its embedment from any edge and six times its embedment from any adjacent anchor. It is highly advisable to utilise preferred anchor sizes and only deviate from this when other circumstances will not allow its use.

No lifting should take place below 7.5 N/mm<sup>2</sup>.



### Calculating the Pin Anchor Load Capacity

The load rating required is determined by the final load value on the anchor. This value is derived from a combination of loads and factors influencing the anchor during the lifting process. These are as follows:

The static or dead weight of the actual concrete unit, this is load **W**.

The quantity, and positioning of anchors with their sling arrangements. The number of effective anchors is divisible into the dead weight of the unit giving the actual weight per anchor **z**.

The angle of lift (angle of sling or chains connecting to anchor from the vertical), this is factor **Sa**.

Removing a unit from the formwork increases the load on the anchor and is related to the surface area of formwork in contact with the concrete. This will influence the mould adhesion factor **Ma**.

The speed at which the unit is hoisted and ground conditions the unit is being transported over. This is the dynamic load factor **V**.

In order to accurately determine the correct size of anchor to be used all these loads and factors have to be combined.

#### Static Weight

This is the actual weight of the concrete and for general purposes is determined from a figure of 2.5 tonnes per cubic metre of concrete. Thus the volume in cubic metres multiplied by a density of 2.5 tonnes/m<sup>3</sup> will give us the unit's static weight **W** in tonnes.

#### Number and Positioning of Anchors and Slings

The weight carried by each anchor is directly affected by the number of anchors being used to carry the unit, and their orientation about the centre of gravity of the unit. It is important that the anchors are placed equidistant about the centre of gravity in any one axis. At this stage it is also worth noting that the number of slings and type of sling system will also affect the load on the anchors. For this reason unless there is some means of balancing the slings, we can only assume that if four slings are connected to four anchors in an unbalanced system, only two anchors effectively take the weight of the unit, therefore half the weight of the unit is being carried by each anchor. The actual static load per anchor **z** is the static weight of the unit **W** divided by the number of effective anchors.

Please see figure 2 giving the number of effective anchors for a specific sling arrangement.

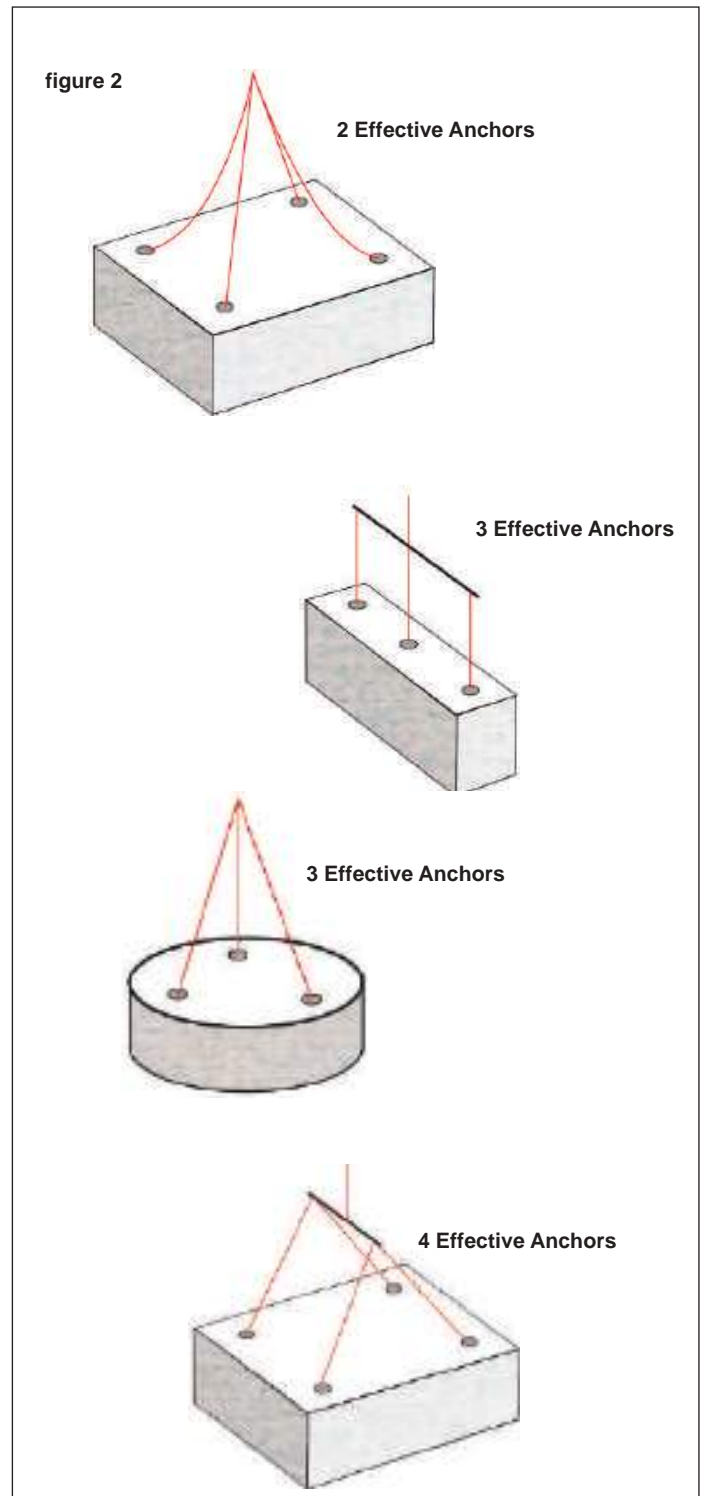

### Angle of Lift

Any inclination of the sling angle from vertical will have a direct result on the load induced on the anchor via the lifting slings. The following values in table 3 and figure 3 apply for this factor **Sa**.

**table 3**  
Single Angle Load Factors

Angle from Vertical a°	Factor Sa
0	1.00
15	1.04
30	1.16
45	1.41
60	2.00

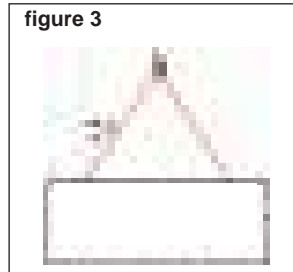

### Removing the Unit from the Formwork

Considerable loads can be induced on the anchors whilst attempting to remove a concrete unit from the formwork (demoulding). This load is influenced greatly by the type of formwork material utilised and the surface area directly in contact with the concrete. The load values per square metre are given in table 4 for various formwork materials. This figure will give us the mould adhesion factor **Ma** and is calculated as follows:

$$Ma = (W + (S \times AI)) / W$$

Where **W** is the static weight of the unit;

Where **S** is the surface area of formwork in contact with the unit in m<sup>2</sup>;

Where **AI** is the load per m<sup>2</sup> for various formwork materials obtained from table 4.

**table 4**  
Demoulding Factors

Formwork Materials	Load per m <sup>2</sup> AI (tonnes)
Flat Steel Shutters	0.1
Flat Plywood Shutters	0.2
Flat Sawn Boards	0.3

For special shaped elements the following factors for **Ma** apply:

Double T Beams **Ma=2.00**

Coffered Slabs **Ma=3.00**

It is important to note that this factor only influences demoulding and plays no part in any general lifting operation and can therefore be ignored for general lifting purposes.

### Speed of Hoist and Transport

Dynamic forces caused by the speed at which a unit is hoisted and the terrain it is transported over also affect the load induced on an anchor. The factor **V** for various rope speeds and terrain are given in table 5.

**table 5**  
Rope Speed and Transport Factors

Lifting Conditions	Factor V
Static crane with rope speed below 90 metres/min	1.00
Static crane with rope speed above 90 metres/min	1.30
Lift and transport with mobile crane on smooth ground	1.75
Lift and transport with mobile crane on uneven ground	2.00
Lift and transport over rough ground	3.00

Note at demould stage the unit is static hence the factor is effectively 1.

It must be noted that the means of lifting and transportation of units utilising the anchors can have a dramatic effect on the final load generated. With this in mind it must be stressed that great consideration must be taken whilst determining this factor. It is important not only to consider factory conditions but the conditions the unit will be handled under, outside the production facility.

### Using the Pin Anchor System in Shear when Tilting or Lifting:

Instances where the Pin Anchor system is being loaded at an angle perpendicular to the long axis of the pin itself, for instance when tilting panels on the ground or lifting from the side of units. A reduction of 50% must be applied to the load capacity of the Pin Anchor, to compensate for shear loads acting on the pin. This restriction can be ignored when tilting panels on the ground, as half of the unit weight is supported by the ground itself. However, where a unit is lifted clear of the ground with the Pin Anchors used in shear, the load capacity must be reduced by 50%.

In practice where a unit is being lifted off the ground in this manner, it is far easier to double the load of the unit in calculations to compensate for this factor, rather than halving figures given in the relevant tables. The capacity of the Pin Anchor Ring Clutch remains unaffected in these situations.





### Calculating The Load Per Anchor

With all these conditions and factors in mind the load rating of the anchor can be calculated as follows:

#### Demoulding:

For demoulding we consider the dead weight per anchor **z**, the mould adhesion factor **Ma** and the increases in load caused by the angle of lift **Sa**. The unit is effectively static at demould stage so dynamic loads need not be considered. The calculation is as follows:

**Load per anchor  $F_e = z \times Ma \times Sa$**

#### General lifting:

For general lifting we consider the dead weight per anchor **z**, the increases in load caused by the angle of lift **Sa** and the dynamic load factor **V**. The calculation is as follows:

**Load per anchor  $F_e = z \times Sa \times V$**

Where:

**z** is the dead weight of the concrete per anchor in tonnes. Derived from **W** divided by the number of effective anchors.

**Ma** demould factor determined from:

$$Ma = (W + (S \times Al))/W.$$

**Sa** is the increased load factor due to sling angles.

**V** is the dynamic load factor due to rope speed and transport conditions.

With this load calculated and if the same anchor is to be used for both demould and lifting, the higher load value should be considered. This value if not an exact match to an available anchor range should be rounded up to the next available. Where concrete dimensions allow, the corresponding preferred length anchor should be utilised.

### Strength of Concrete and Resistance to Pull Out Forces

Once the correct load rating of the required anchor is calculated, we need to assess the ability of the surrounding concrete to resist pull out forces. This is influenced by several factors, such as its compressive strength, the position of anchors in relation to any edges and the position of adjacent anchors. The optimum pull out resistance **Po** for the Pin Anchor system is achieved when the anchor is placed a distance at least three times its embedded depth **E** from any edge and at least six times its embedded depth **E** from any adjacent anchor. This is based on the flat pull out cone that this type of anchor produces. This ratio remains constant throughout the size range but the optimum pull out value is affected by the compressive strength of the concrete. The pull out values **Po** for varying concrete strengths can be checked in the following tables 6 and 7.

The influences of these factors are covered on the following pages. Please note: providing the minimum edge distances and centre to centre distances are met and the pull-out value relative to concrete strength is sufficient to meet the demands calculated for the load on the anchor, the following sections can be largely ignored. Note: **E** is derived from anchor length **L** + Concrete Cover **C**.

## Optimum Pull Out Values for Various Anchors in Relation to Concrete Strength

**table 6**

Optimum Pull Out Values  $P_o$  (tonnes) in Relation to Concrete Strength  $B$

Load Capacity (tonnes)	Anchor Length L (mm)	Embedded Depth E (mm)	Concrete Compressive Strength $B$						
			7.5 N/mm <sup>2</sup>	10 N/mm <sup>2</sup>	15 N/mm <sup>2</sup>	20 N/mm <sup>2</sup>	30 N/mm <sup>2</sup>	40 N/mm <sup>2</sup>	50 N/mm <sup>2</sup>
1.3	40	50	0.35	0.43	0.56	0.68	0.89	1.08	1.26
1.3	50	60	0.51	0.62	0.82	0.99	1.30	1.58	1.84
1.3	55	65	0.61	0.74	0.97	1.17	1.54	1.86	2.17
1.3	65	75	0.82	0.99	1.30	1.57	2.06	2.50	2.91
1.3	85	95	1.32	1.61	2.11	2.55	3.35	4.06	4.72
<b>1.3</b>	<b>120</b>	<b>130</b>	<b>2.51</b>	<b>3.04</b>	<b>3.99</b>	<b>4.84</b>	<b>6.35</b>	<b>7.70</b>	<b>8.94</b>
2.5	45	56	0.48	0.58	0.76	0.93	1.21	1.47	1.71
2.5	55	66	0.67	0.81	1.06	1.29	1.69	2.05	2.38
2.5	85	96	1.41	1.71	2.24	2.72	3.57	4.33	5.03
2.5	120	131	2.63	3.18	4.18	5.07	6.65	8.06	9.36
<b>2.5</b>	<b>170</b>	<b>181</b>	<b>5.01</b>	<b>6.08</b>	<b>7.98</b>	<b>9.67</b>	<b>12.69</b>	<b>15.39</b>	<b>17.87</b>
2.5	280	291	12.96	15.71	20.62	25.00	32.81	39.78	46.20
5.0	75	90	1.24	1.50	1.97	2.39	3.14	3.81	4.42
5.0	95	110	1.85	2.25	2.95	3.57	4.69	5.68	6.60
5.0	120	135	2.79	3.38	4.44	5.38	7.06	8.56	9.94
5.0	180	195	5.82	7.06	9.26	11.23	14.73	17.86	20.74
<b>5.0</b>	<b>240</b>	<b>255</b>	<b>9.95</b>	<b>12.07</b>	<b>15.83</b>	<b>19.20</b>	<b>25.19</b>	<b>30.55</b>	<b>35.47</b>
5.0	340	355	19.29	23.39	30.69	37.21	48.83	59.20	68.75
5.0	480	495	37.50	45.50	59.70	72.30	94.90	115.10	133.70
7.5	85	100	1.53	1.86	2.44	2.95	3.87	4.70	5.46
7.5	120	135	2.79	3.38	4.44	5.38	7.06	8.56	9.94
<b>7.5</b>	<b>300</b>	<b>315</b>	<b>15.19</b>	<b>18.41</b>	<b>24.16</b>	<b>29.30</b>	<b>38.44</b>	<b>45.61</b>	<b>54.13</b>
7.5	540	555	47.10	57.20	75.00	90.90	119.30	144.70	168.00
10.0	120	135	2.79	3.38	4.44	5.38	7.06	8.56	9.94
10.0	170	185	5.24	6.35	8.33	10.11	13.26	16.08	18.67
<b>10.0</b>	<b>340</b>	<b>355</b>	<b>19.29</b>	<b>23.39</b>	<b>30.69</b>	<b>37.21</b>	<b>48.83</b>	<b>59.20</b>	<b>68.75</b>
10.0	680	695	73.90	89.60	117.60	142.60	187.10	226.90	263.50
15.0	120	135	2.83	3.43	4.50	5.46	7.17	8.69	10.09
15.0	150	165	4.22	5.11	6.71	8.14	10.68	12.95	15.03
15.0	170	185	5.29	6.42	8.42	10.21	13.40	16.25	18.87
15.0	220	235	8.52	10.34	13.56	16.44	21.58	26.17	30.38
15.0	300	315	15.29	18.46	24.21	30.01	38.53	45.74	54.26
<b>15.0</b>	<b>400</b>	<b>415</b>	<b>26.48</b>	<b>32.11</b>	<b>42.14</b>	<b>51.10</b>	<b>67.05</b>	<b>81.30</b>	<b>94.41</b>
15.0	480	495	37.65	45.65	59.91	72.64	95.31	115.57	134.21
20.0	250	265	10.83	13.13	17.23	20.89	27.41	33.24	38.60
20.0	340	355	19.50	23.50	30.90	37.40	49.10	59.50	69.10
<b>20.0</b>	<b>500</b>	<b>515</b>	<b>40.75</b>	<b>49.41</b>	<b>64.83</b>	<b>78.62</b>	<b>103.16</b>	<b>125.08</b>	<b>145.25</b>
32.0	200	227	7.90	9.60	12.50	15.20	20.00	24.20	28.10
32.0	280	307	14.40	17.50	23.00	27.80	36.50	44.30	51.40
<b>32.0</b>	<b>700</b>	<b>727</b>	<b>80.90</b>	<b>98.10</b>	<b>128.70</b>	<b>156.10</b>	<b>204.80</b>	<b>248.30</b>	<b>288.30</b>
32.0	1220	1247	230.40	279.40	366.60	441.50	583.30	707.30	821.30

Notes: Dimensions in **bold** text are preferred lengths.



**Optimum Pull Out Values for Various Embedment Depths in Relation to Concrete Strength**

**table 7**  
Optimum Pull Out Values **Po** (tonnes) for Various Embedment Depths **E**

Embedment E (mm)	Concrete Strength B						
	10 N/mm <sup>2</sup>	15 N/mm <sup>2</sup>	20 N/mm <sup>2</sup>	30 N/mm <sup>2</sup>	40 N/mm <sup>2</sup>	50 N/mm <sup>2</sup>	60 N/mm <sup>2</sup>
45	0.4	0.5	0.6	0.8	1.0	1.1	1.2
50	0.5	0.6	0.7	1.0	1.2	1.4	1.5
55	0.6	0.7	0.9	1.2	1.4	1.7	1.9
60	0.7	0.9	1.1	1.4	1.7	2.0	2.2
65	0.8	1.0	1.2	1.6	2.0	2.3	2.6
70	0.9	1.2	1.4	1.9	2.3	2.7	3.0
75	1.0	1.4	1.7	2.2	2.6	3.1	3.5
80	1.2	1.6	1.9	2.5	3.0	3.5	3.9
85	1.3	1.8	2.1	2.8	3.4	3.9	4.5
90	1.5	2.0	2.4	3.1	3.8	4.4	5.0
95	1.7	2.2	2.7	3.5	4.2	4.9	5.6
100	1.9	2.4	3.0	3.9	4.7	5.5	6.2
105	2.0	2.7	3.3	4.3	5.2	6.0	6.8
110	2.2	2.9	3.6	4.7	5.7	6.6	7.5
115	2.5	3.2	3.9	5.1	6.2	7.2	8.2
120	2.7	3.5	4.3	5.6	6.8	7.9	8.9
125	2.9	3.8	4.6	6.1	7.3	8.5	9.6
130	3.1	4.1	5.0	6.5	7.9	9.2	10.4
135	3.4	4.4	5.4	7.1	8.6	9.9	11.2
140	3.6	4.8	5.8	7.6	9.2	10.7	12.1
145	3.9	5.1	6.2	8.1	9.9	11.5	13.0
150	4.2	5.5	6.6	8.7	10.6	12.3	13.9
155	4.5	5.9	7.1	9.3	11.3	13.1	14.8
160	4.8	6.2	7.6	9.9	12.0	14.0	15.8
165	5.1	6.6	8.0	10.5	12.8	14.9	16.8
170	5.4	7.0	8.5	11.2	13.6	15.8	17.8
175	5.7	7.5	9.0	11.9	14.4	16.7	18.9
180	6.0	7.9	9.6	12.6	15.2	17.7	20.0
185	6.4	8.3	10.1	13.3	16.1	18.7	21.1
190	6.7	8.8	10.7	14.0	17.0	19.7	22.3
195	7.1	9.3	11.2	14.7	17.9	20.7	23.4
200	7.4	9.7	11.8	15.5	18.8	21.8	24.7

### Edge Distances Affecting Pull Out Values

When an anchor is placed close to an edge and the minimum dimension of three times the anchor embedment **E** is not fulfilled, then reductions in pull out capacity occur. These reductions are based on the ratio of the actual edge distance available **Ed** to the anchor embedment **E**. The reduction factor **Ef** is obtained from Graph A from the value **Ed/E**.

This reduction should be considered for all edges adjacent to the anchor. The final reduction factor **Rf** is the product obtained from the four values of **Ef** for edges adjacent to the anchor. Please note that where the anchor is placed three or more times its embedment depth from an edge, the reduction factor **Ef** for that edge is always 1.

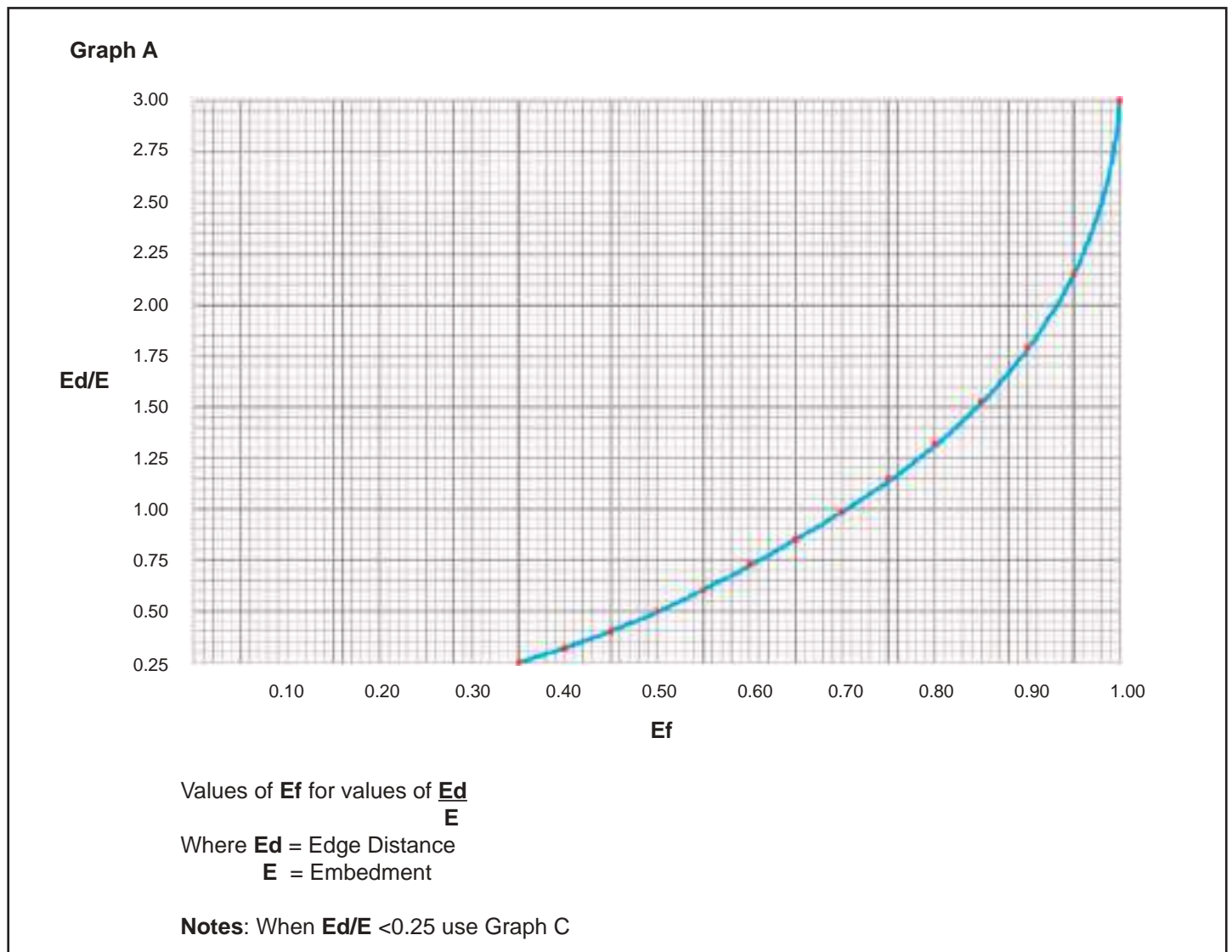



**Adjacent Anchors Affecting Pull Out Values**

Where an anchor is placed a distance less than six times its embedment **E** from an adjacent anchor, similarly there are reductions in the pull out capacity of the concrete. The reduction factors **Sf** are based on the ratio of **T/E** and can be obtained from Graph B. please note that **T** is half the distance between the two anchors.

They should represent a replacement of one or two of the edge distance factors **Ef** in the previous section. The final reduction factor **Rf** is obtained from the product of these four factors. Where any anchor is more than six times its embedded length from an adjacent anchor the value for **Sf** in that direction is 1.

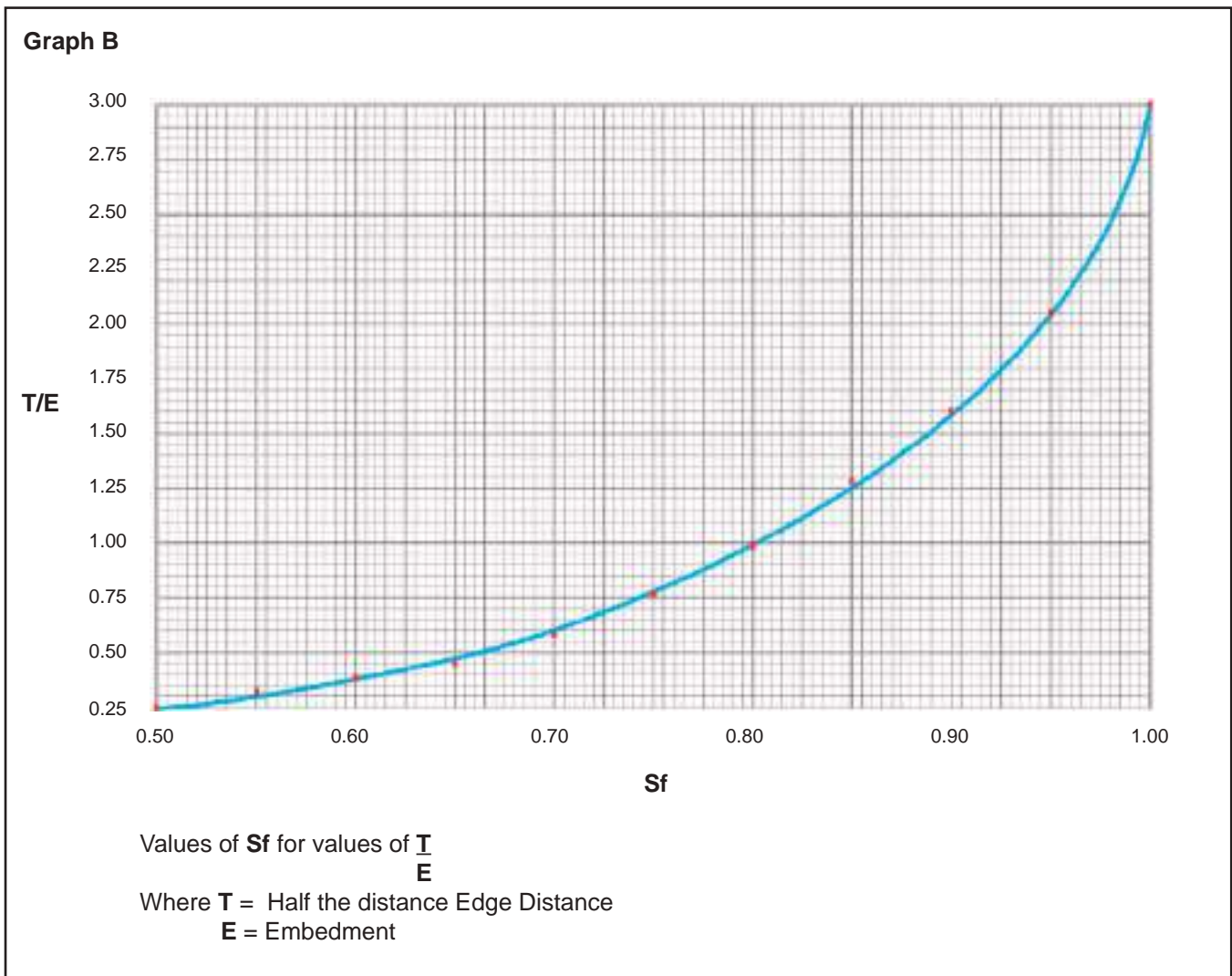

### Examples For Determining Reduction Factors

From the following three figures the reduction factor is calculated as follows.

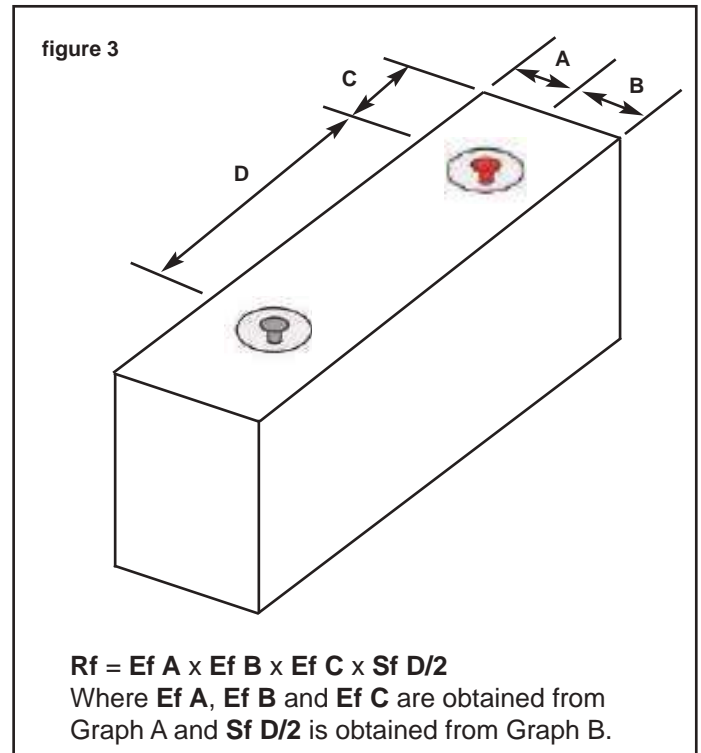
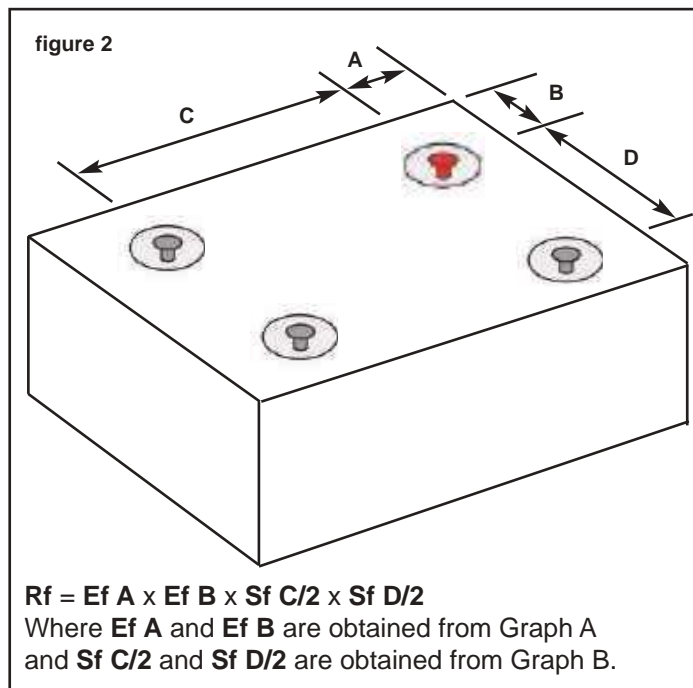
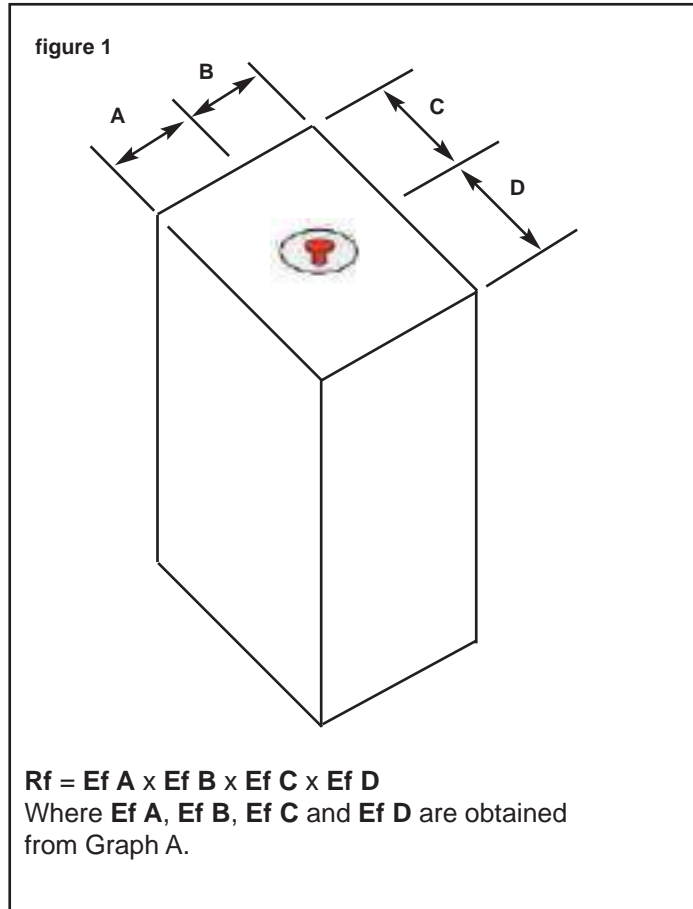

In any given direction where optimum spacing is not possible due to the dimensions of a unit, it is preferable to increase edge distances over centre to centre distances. In this instance allow one third of the space available, for edge distance to each anchor. The remaining third being the distance between the two anchors.

To calculate the size of anchor required, simply divide the load per anchor value  $F_e$  by the load reduction factor  $R_f$ . This will give us the minimum pull out capacity requirements for  $P_o$  and should be compared with the values in tables 6 and 7, giving us the optimum anchor length and concrete strength. Alternately the  $P_o$  value from tables 6 and 7 can be multiplied by the load reduction factor  $R_f$  until a suitable value for  $F_e$  is matched, though this is more a case of elimination.



**Reductions in Pull Out Values for Narrow Panels**

Where anchors are to be used in very narrow panels (where the panel thickness is less than 50% of the proposed anchor embedment depth) further reductions must be applied to the values in tables 6 and 7. This reduction factor **X** can be obtained from Graph C and is a function of the wall thickness in relation to concrete strength. This factor is multiplied by the values for **P<sub>o</sub>** in tables 6 and 7 to give the optimum pull out strength of the anchor in that particular placement. With the anchor positioned in the centre of the narrow width, the ideal placement of the anchor for edge distance should be

three times it's embedment **E** and six times it's embedment from any other anchor. If this criteria cannot be met then reductions in anchor pull out capacities should be calculated for the edge distance and centres of anchor as previously examined. Note, as we have already calculated the reduction in two directions for the narrow panel, we only need to look at two directions of reduction. This further reduction factor is applied to the reduced optimum pull out strength already calculated for the narrow panel. It is imperative that narrow units are not lifted below a concrete strength of 10 N/mm<sup>2</sup>.

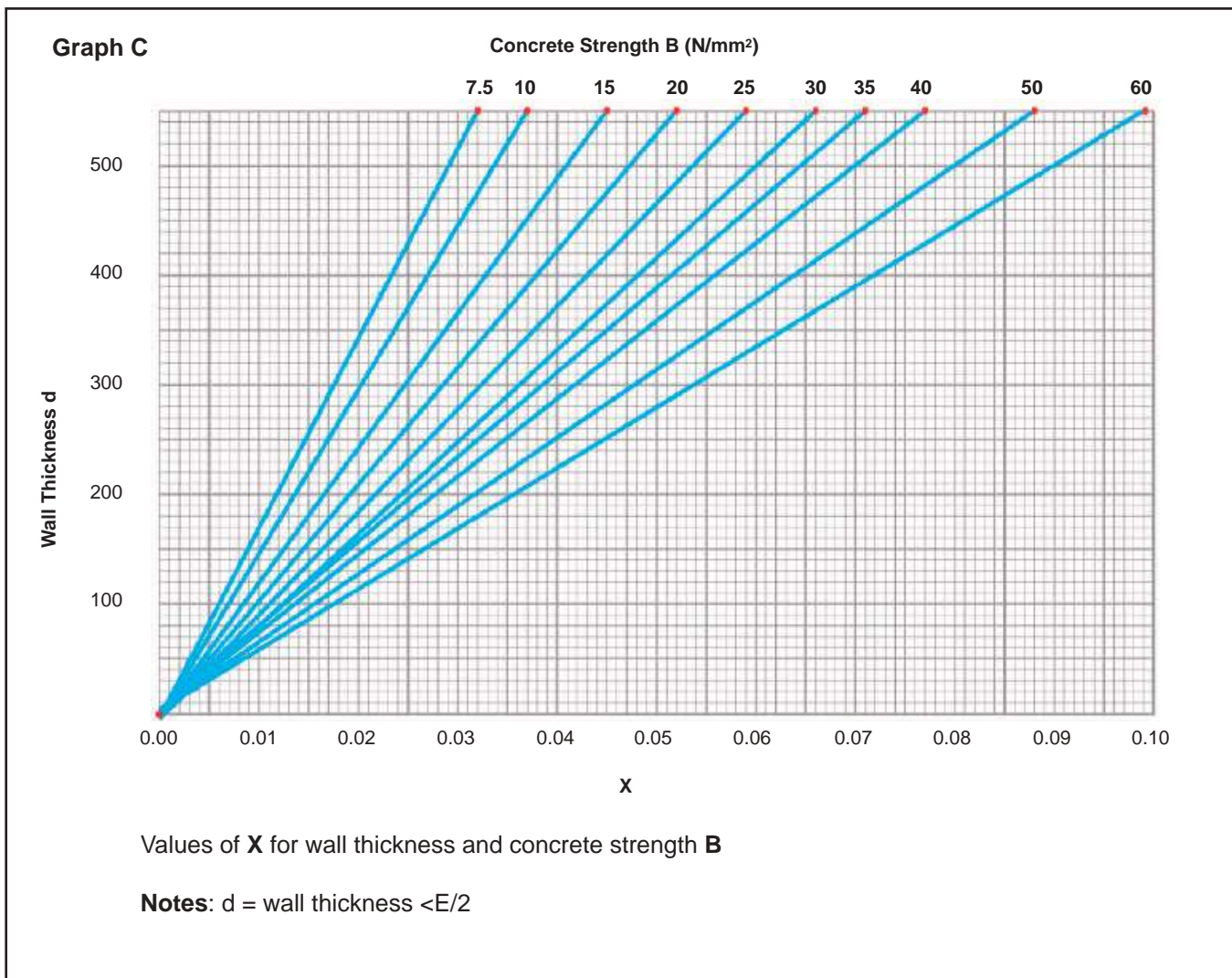

### Face Failure

Face failure can occur when an anchor is placed in a thin section of concrete. Loads exerted on the anchor can cause cracking or bursting of the concrete in the area closest to the base of the anchor, where the load is transferred into the concrete. In order to alleviate this, minimum edge distances as per table 8 should be observed. If these edge distances cannot be met then an alternative combination of anchor length and concrete strength corresponding to the available edge distance, should be chosen from table 9 (page 15). The face failure value must be higher than the required load per anchor  $F_e$  calculated previously.

**table 8**  
Face Failure Minimum Edge Distances

Load Capacity (tonnes)	Minimum Edge Distance (mm)
1.3	40
2.5	60
5.0	85
7.5	105
10.0	115
15.0	140
20.0	165
32.0	255

### Additional Reinforcement Requirements

Whilst the Pin Anchor system load values relate to unreinforced concrete, in certain instances where narrow panels are being turned from horizontal plane to the vertical plane, shear loads perpendicular to the axis of the anchor can result in the anchor tearing sideways out of the concrete. With this in mind it is necessary to introduce additional reinforcement. This can be straight or bent to lap into any existing mesh reinforcement in the panel. It should oppose the lifting forces and be fixed as close to the head of the Pin Anchor as practically possible. The length and diameter of the reinforcement should be in accordance with table 10.

**table 10**  
Additional Reinforcement for Tilting Narrow Panels

Load Capacity (tonnes)	Load Capacity for Turning (tonnes)	Bar Dia. (mm)	Total Length (mm)
1.3	0.65	8	500
2.5	1.25	10	600
5.0	2.50	16	975
7.5	3.75	20	1200
10.0	5.00	20	1200
15.0	7.50	25	1500
20.0	10.0	32	1925
32.0	16.0	40	2400

There is also a danger when tilting units with very small edge distances that the small area of concrete between the edge of the preformed pocket and the edge of the unit

can break away due to loads induced on the concrete by the Pin Anchor Ring Clutch. If edge distances are not in accordance with the following table 11 then additional reinforcement as per sketch below should be utilised.

**table 11**  
Minimum Edge Distances and Additional Reinforcement for Tilting Thin Panels without Nib Damage

Load Capacity (tonnes)	Minimum Edge Distance (mm)	Bar Diameter (mm)	Total Length (mm)
1.3	60	8	800
2.5	80	10	1120
5.0	100	16	1600
7.5	130	20	1750
10.0	130	20	1750
15.0	180	25	2000
20.0	180	25	2000
32.0	250	32	2600

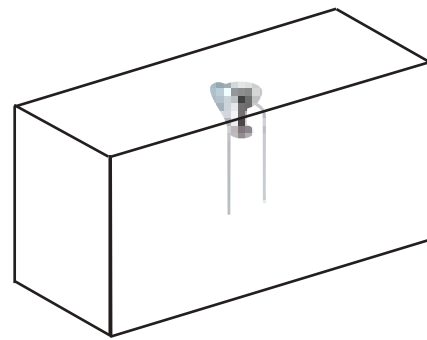

### Summary

When utilising the Pin Anchor system the following should be considered:

- The actual load on the anchor, taking into account all elements that will influence this load such as the number of anchors, their placement, sling angles, demoulding forces and any dynamic loading forces.
- The load rating and length of the Pin Anchor. Where possible a preferred length Pin Anchor should be selected and placed with optimum edge distances and anchor spacings.
- The reduction in pull out strengths in flat panels due to reduced edge distances and anchor spacings.
- The reduction in pull out capacity for narrow elements.
- The possibility of face failure with narrow elements.
- Additional reinforcement requirements when tilting narrow units.





**table 9**  
Face Failure Values for Thin Panels

Load Capacity (tonnes)	Edge Distance (mm)	Concrete Strength B						
		10 N/mm <sup>2</sup>	15 N/mm <sup>2</sup>	20 N/mm <sup>2</sup>	30 N/mm <sup>2</sup>	10 N/mm <sup>2</sup>	15 N/mm <sup>2</sup>	20 N/mm <sup>2</sup>
		Anchor Length 120mm			Anchor Length 240mm			
1.3	25	0.58	0.79	0.99	1.35	0.66	0.90	1.11
1.3	30	0.74	1.00	1.24	-	0.82	1.10	-
1.3	35	0.92	1.24	-	-	1.00	-	-
1.3	40	1.14	-	-	-	1.22	-	-
		Anchor Length 170mm			Anchor Length 280mm			
2.5	30	0.96	1.31	1.65	2.27	1.06	1.45	1.81
2.5	35	1.15	1.56	1.94	2.66	1.25	1.69	2.11
2.5	40	1.36	1.84	2.29	-	1.46	1.98	2.45
2.5	45	1.60	2.16	-	-	1.71	2.29	-
2.5	50	1.87	2.52	-	-	1.98	-	-
2.5	55	2.17	-	-	-	2.28	-	-
		Anchor Length 240mm			Anchor Length 480mm			
5.0	50	2.34	3.19	3.97	5.44	2.66	3.61	4.48
5.0	60	2.97	4.01	4.98	-	3.29	4.43	5.48
5.0	70	3.71	4.99	-	-	4.03	5.41	-
5.0	80	4.57	-	-	-	4.89	-	-
		Anchor Length 300mm			Anchor Length 540mm			
7.5	50	2.75	3.77	4.73	6.54	3.13	4.28	5.34
7.5	60	3.38	4.60	5.74	7.86	3.77	5.11	6.35
7.5	70	4.13	5.58	6.92	9.41	4.51	6.08	7.53
7.5	80	4.98	6.70	-	-	5.37	7.21	-
7.5	90	5.95	-	-	-	6.35	-	-
7.5	100	7.04	-	-	-	7.42	-	-
		Anchor Length 340mm			Anchor Length 680mm			
10	50	3.22	4.45	5.61	7.81	3.85	5.28	6.62
10	60	3.85	5.28	6.61	9.13	4.49	6.11	7.63
10	70	4.60	6.26	7.80	-	5.23	7.09	8.81
10	80	5.46	7.38	9.17	-	6.09	8.22	-
10	90	6.43	8.66	-	-	7.06	9.49	-
10	100	7.51	-	-	-	8.15	-	-
10	110	8.71	-	-	-	9.35	-	-
		Anchor Length 400mm			Anchor Length 840mm			
15	70	5.39	7.40	9.30	12.86	6.39	8.71	10.88
15	80	6.25	8.53	10.67	14.66	7.25	9.84	12.25
15	90	7.23	9.81	12.22	-	8.22	11.12	13.81
15	100	8.31	11.24	13.95	-	9.31	12.55	-
15	110	9.51	12.82	-	-	10.51	14.12	-
15	120	10.83	14.54	-	-	11.83	-	-
15	130	12.25	-	-	-	13.25	-	-
15	140	13.79	-	-	-	14.79	-	-
		Anchor Length 500mm			Anchor Length 1000mm			
20	80	7.20	9.88	12.40	17.19	8.50	11.58	14.47
20	100	9.26	12.59	15.68	-	10.56	14.30	17.75
20	120	11.78	15.89	19.69	-	13.08	17.60	-
20	140	14.75	19.79	-	-	16.05	-	-
20	160	18.71	-	-	-	19.47	-	-
		Anchor Length 700mm			Anchor Length 1200mm			
32	80	9.67	13.41	16.95	23.66	11.34	15.60	19.60
32	100	11.75	16.13	20.25	28.00	14.42	18.32	22.90
32	120	14.28	19.45	24.27	-	15.95	21.64	26.93
32	140	17.28	23.36	29.01	-	18.93	25.55	31.67
32	160	20.69	27.86	-	-	22.36	30.05	-
32	180	24.57	-	-	-	26.24	-	-
32	200	28.91	-	-	-	-	-	-

### Lifting Pipe Units

Where the Pin Anchor system is utilised in concrete pipe elements the load values and concrete strengths as per table 12 should be referred to. The anchors must be

placed along the central axis of the pipe and must have an edge distance **Ed** equal to 3 times the anchor embedment for the size range utilised, and 6 times the embedment for anchor spacing.

**table 12**

Permissible Loads for Various Anchor Lengths, Concrete Strengths and Pipe Diameters (tonnes)

Pipe Diameter (mm)	Anchor length (mm)	Permissible Load (tonnes) and Concrete Strength B					
		25 N/mm <sup>2</sup>	35 N/mm <sup>2</sup>	45 N/mm <sup>2</sup>	55 N/mm <sup>2</sup>	60 N/mm <sup>2</sup>	70 N/mm <sup>2</sup>
>300	40	0.72	0.91	1.07	1.23	1.29	1.43
	45	0.86	1.08	1.28	1.47	1.54	1.71
	50	1.01	1.26	1.49	1.71	1.81	2.01
>500	40	0.77	0.97	1.15	1.31	1.38	1.53
	45	0.92	1.16	1.37	1.57	1.65	1.83
	50	1.08	1.35	1.60	1.83	1.94	2.15
	55	1.26	1.57	1.86	2.13	2.27	2.51
>700	50	1.13	1.41	1.67	1.91	2.03	2.25
	55	1.31	1.64	1.94	2.22	2.36	2.61
	65	1.70	2.14	2.53	2.89	3.05	3.39
	75	2.15	2.69	3.18	3.64	3.86	4.28
>900	75	2.41	3.02	3.57	4.09	4.33	4.60
	95	3.50	4.39	5.19	5.94	6.29	6.97
	120	5.12	6.42	7.59	8.69	9.20	10.20
>1100	75	2.47	3.09	3.66	4.19	4.44	4.92
	95	3.60	4.50	5.33	6.10	6.47	7.17
	120	5.27	6.60	7.81	8.94	9.47	10.50
>1400	120	5.44	6.82	8.07	9.23	9.78	10.84
>1800	170	10.12	12.68	15.01	17.17	18.19	20.17



## Pin Anchors

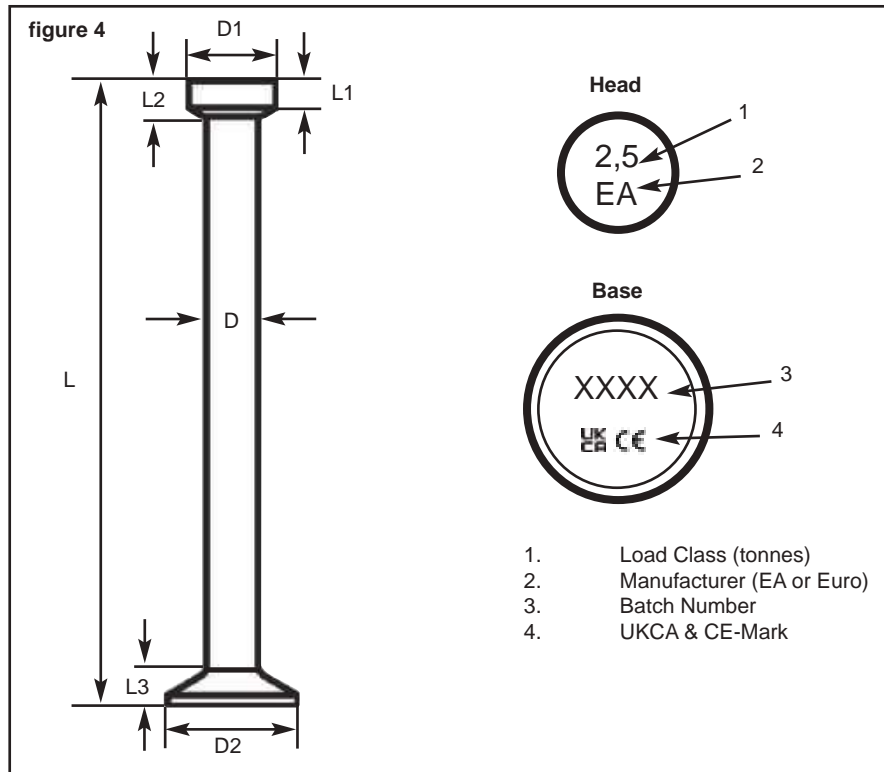

These anchors are forged from round mild steel. They are offered in either mild steel, hot dip galvanised or stainless steel (grade 304) finish. Each item is clearly marked with Euro Accessories branding, it's maximum safe working load, CE marking and batch number. Please refer to table 13 and figure 4 for relevant details.

The capability of the surrounding concrete to withstand lifting loads should always be considered before lifting commences.

**table 13**  
Pin Anchor Dimensions

Load Capacity (tonnes)	Anchor Length L (mm)	D (mm)	D1 (mm)	D2 (mm)	L1 (mm)	L2 (mm)	L3 (mm)
1.3	55	10	18	25	5.0	8.0	5.0
1.3	40	10	18	25	5.0	8.0	5.0
1.3	50	10	18	25	5.0	8.0	5.0
1.3	55	10	18	25	5.0	8.0	5.0
1.3	65	10	18	25	5.0	8.0	5.0
1.3	85	10	18	25	5.0	8.0	5.0
1.3	120	10	18	25	5.0	8.0	5.0
1.3	240	10	18	25	5.0	8.0	5.0
2.5	45	14	25	35	7.0	10.0	7.0
2.5	55	14	25	35	7.0	10.0	7.0
2.5	65	14	25	35	7.0	10.0	7.0
2.5	70	14	25	35	7.0	10.0	7.0
2.5	85	14	25	35	7.0	10.0	7.0
2.5	100	14	25	35	7.0	10.0	7.0
2.5	120	14	25	35	7.0	10.0	7.0
2.5	140	14	25	35	7.0	10.0	7.0
2.5	170	14	25	35	7.0	10.0	7.0
2.5	180	14	25	35	7.0	10.0	7.0
2.5	240	14	25	35	7.0	10.0	7.0
2.5	280	14	25	35	7.0	10.0	7.0
5.0	50	20	36	50	8.5	13.0	10.0
5.0	65	20	36	50	8.5	13.0	10.0
5.0	80	20	36	50	8.5	13.0	10.0
5.0	85	20	36	50	8.5	13.0	10.0
5.0	95	20	36	50	8.5	13.0	10.0
5.0	100	20	36	50	8.5	13.0	10.0
5.0	110	20	36	50	8.5	13.0	10.0
5.0	120	20	36	50	8.5	13.0	10.0
5.0	140	20	36	50	8.5	13.0	10.0

**table 13 continued**  
Pin Anchor Dimensions

Load Capacity (tonnes)	Anchor Length L (mm)	D (mm)	D1 (mm)	D2 (mm)	L1 (mm)	L2 (mm)	L3 (mm)
5.0	150	20	36	50	8.5	13.0	10.0
5.0	160	20	36	50	8.5	13.0	10.0
5.0	170	20	36	50	8.5	13.0	10.0
5.0	180	20	36	50	8.5	13.0	10.0
5.0	210	20	36	50	8.5	13.0	10.0
5.0	240	20	36	50	8.5	13.0	10.0
5.0	340	20	36	50	8.5	13.0	10.0
5.0	480	20	36	50	8.5	13.0	10.0
7.5	85	24	46	60	11.0	18.0	13.0
7.5	95	24	46	60	11.0	18.0	13.0
7.5	100	24	46	60	11.0	18.0	13.0
7.5	120	24	46	60	11.0	18.0	13.0
7.5	140	24	46	60	11.0	18.0	13.0
7.5	150	24	46	60	11.0	18.0	13.0
7.5	160	24	46	60	11.0	18.0	13.0
7.5	165	24	46	60	11.0	18.0	13.0
7.5	240	24	46	60	11.0	18.0	13.0
7.5	300	24	46	60	11.0	18.0	13.0
7.5	540	24	46	60	11.0	18.0	13.0
10.0	85	28	46	70	12.0	18.0	14.0
10.0	100	28	46	70	12.0	18.0	14.0
10.0	110	28	46	70	12.0	18.0	14.0
10.0	115	28	46	70	12.0	18.0	14.0
10.0	120	28	46	70	12.0	18.0	14.0
10.0	135	28	46	70	12.0	18.0	14.0
10.0	150	28	46	70	12.0	18.0	14.0
10.0	170	28	46	70	12.0	18.0	14.0
10.0	200	28	46	70	12.0	18.0	14.0
10.0	220	28	46	70	12.0	18.0	14.0
10.0	250	28	46	70	12.0	18.0	14.0
10.0	340	28	46	70	12.0	18.0	14.0
10.0	650	28	46	70	12.0	18.0	14.0
10.0	680	28	46	70	12.0	18.0	14.0
15.0	140	34	69	80	14.0	27.0	17.0
15.0	150	34	69	85	14.0	27.0	17.0
15.0	165	34	69	85	14.0	27.0	17.0
15.0	200	34	69	85	14.0	27.0	17.0
15.0	210	34	69	85	14.0	27.0	17.0
15.0	300	34	69	85	14.0	27.0	17.0
15.0	400	34	69	85	14.0	27.0	17.0
15.0	840	34	69	85	14.0	27.0	17.0
20.0	165	38	69	98	14.5	27.0	20.0
20.0	200	38	69	98	14.5	27.0	20.0
20.0	250	38	69	98	14.5	27.0	20.0
20.0	340	38	69	98	14.5	27.0	20.0
20.0	500	38	69	98	14.5	27.0	20.0
20.0	1000	38	69	98	14.5	27.0	20.0
32.0	175	50	88	135	25.0	36.0	30.0
32.0	280	50	88	135	25.0	36.0	30.0
32.0	500	50	88	135	25.0	36.0	30.0
32.0	700	50	88	135	25.0	36.0	30.0
32.0	1200	50	88	135	25.0	36.0	30.0



## Pipe Pin Anchors

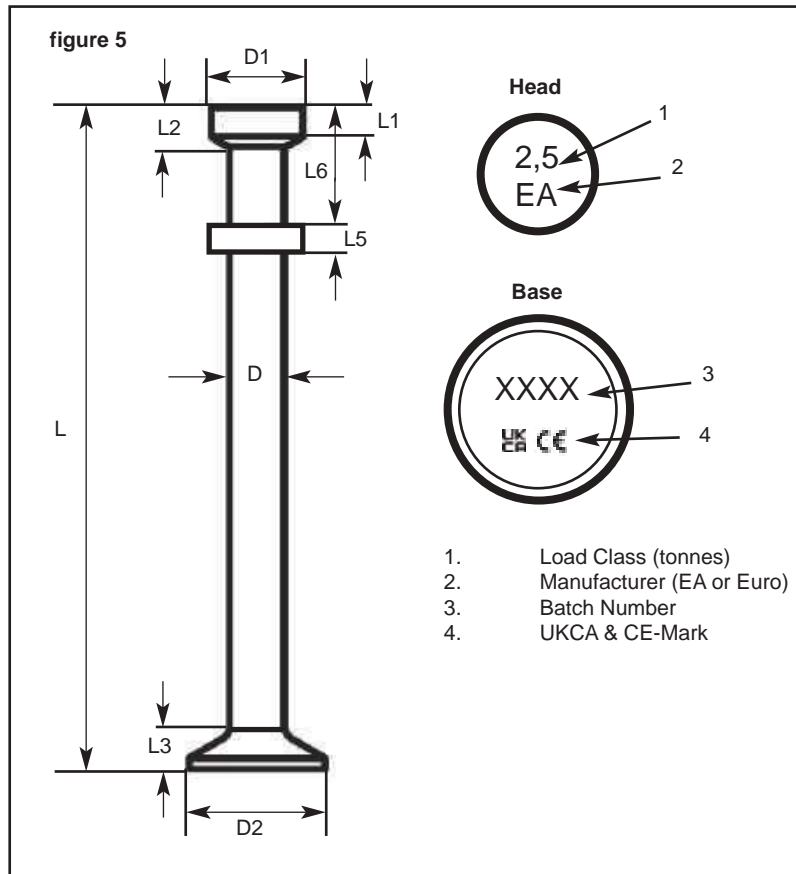

With more automation called for in the rapid production of pipe units, the Pipe Pin Anchor facilitates the placement of lifting points by an automated process. It can be used in conjunction with the steel recess former. Use should be in accordance with the general pin anchor guidance. The capability of the surrounding concrete to withstand lifting loads should always be considered before lifting commences. See table 14 and figure 5 for relevant details.

These anchors are forged from round mild steel. They are offered in either mild steel, hot dip galvanised or stainless steel (grade 304) finish. Each item is clearly marked with Euro Accessories branding, it's maximum safe working load, CE marking and batch number.

**table 14**  
Pipe Pin Anchor Dimensions

Load Capacity (tonnes)	Anchor Length L (mm)	D (mm)	D1 (mm)	D2 (mm)	L1 (mm)	L2 (mm)	L3 (mm)	L5 (mm)	L6 (mm)
1.3	55	10	18	25	5.0	8	5	4	19
1.3	85	10	18	25	5.0	8	5	4	19
1.3	120	10	18	25	5.0	8	5	4	19
2.5	55	14	25	35	7.0	10	7	6	24
2.5	85	14	25	35	7.0	10	7	6	24
2.5	110	14	25	35	7.0	10	7	6	24
2.5	120	14	25	35	7.0	10	7	6	24
2.5	170	14	25	35	7.0	10	7	6	24
5.0	75	20	36	50	8.5	13	10	9	29
5.0	120	20	36	50	8.5	13	10	9	29
5.0	240	20	36	50	8.5	13	10	9	29

# Plate Pin Anchors

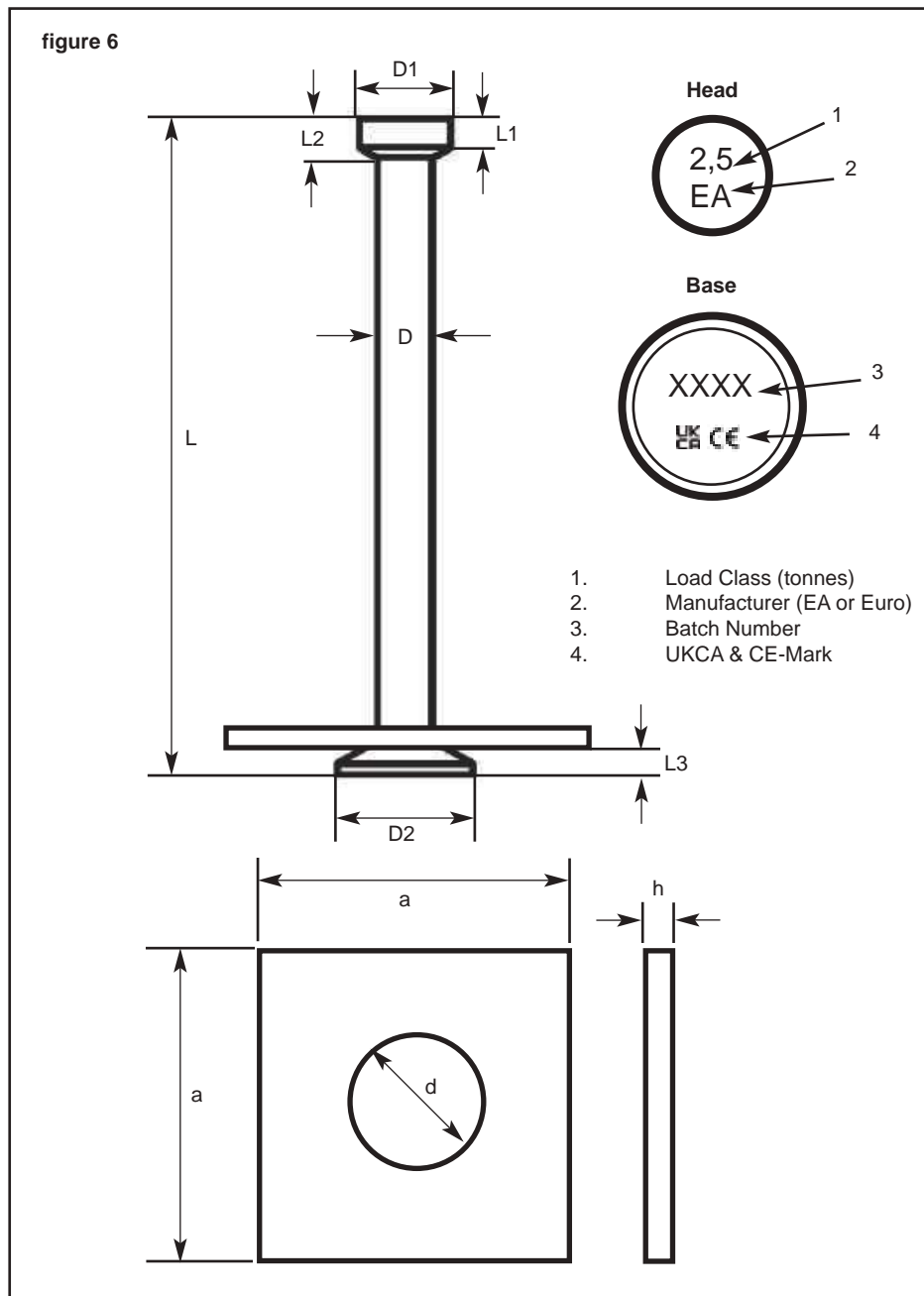

Designed for lifting very shallow slab units, this anchor utilises 4 additional reinforcement bars, see table 15, placed in pairs over the integral plate to transfer loads into the surrounding concrete.

These anchors are forged from round mild steel. They are offered in either mild steel, hot dip galvanised or stainless steel (grade 304) finish. Each item is clearly marked with Euro Accessories branding, it's maximum safe working load, CE marking and batch number.

The capability of the surrounding concrete to withstand lifting loads should always be considered before lifting commences. Consult table 16 and figure 6 for relevant details.

**table 15**  
Additional Reinforcement for Plate Pin Anchors

Load Capacity (tonnes)	Anchor Length (mm)	Qty x Bar Dia. (mm)	Bar Length (mm)
2.5	55	4no x 8	200
2.5	85	4no x 10	250
2.5	120	4no x 10	300
5.0	55	4no x 12	450
5.0	65	4no x 12	450
5.0	95	4no x 12	450
5.0	110	4no x 12	450
10.0	115	4no x 16	600

**table 16**  
Plate Pin Anchor Dimensions

Load Capacity (tonnes)	Anchor Length L (mm)	D (mm)	D1 (mm)	D2 (mm)	L1 (mm)	L2 (mm)	L3 (mm)	a (mm)	d (mm)	h (mm)
2.5	55	14	25	35	7.0	10	7	70	28	6
2.5	85	14	25	35	7.0	10	7	70	28	6
2.5	120	14	25	35	7.0	10	7	70	28	6
5.0	55	20	36	50	8.5	13	10	90	38	8
5.0	65	20	36	50	8.5	13	10	90	38	8
5.0	95	20	36	50	8.5	13	10	90	38	8
5.0	110	20	36	50	8.5	13	10	90	38	8
10.0	115	28	46	70	12.0	18	14	90	48	10



## Eye Anchors

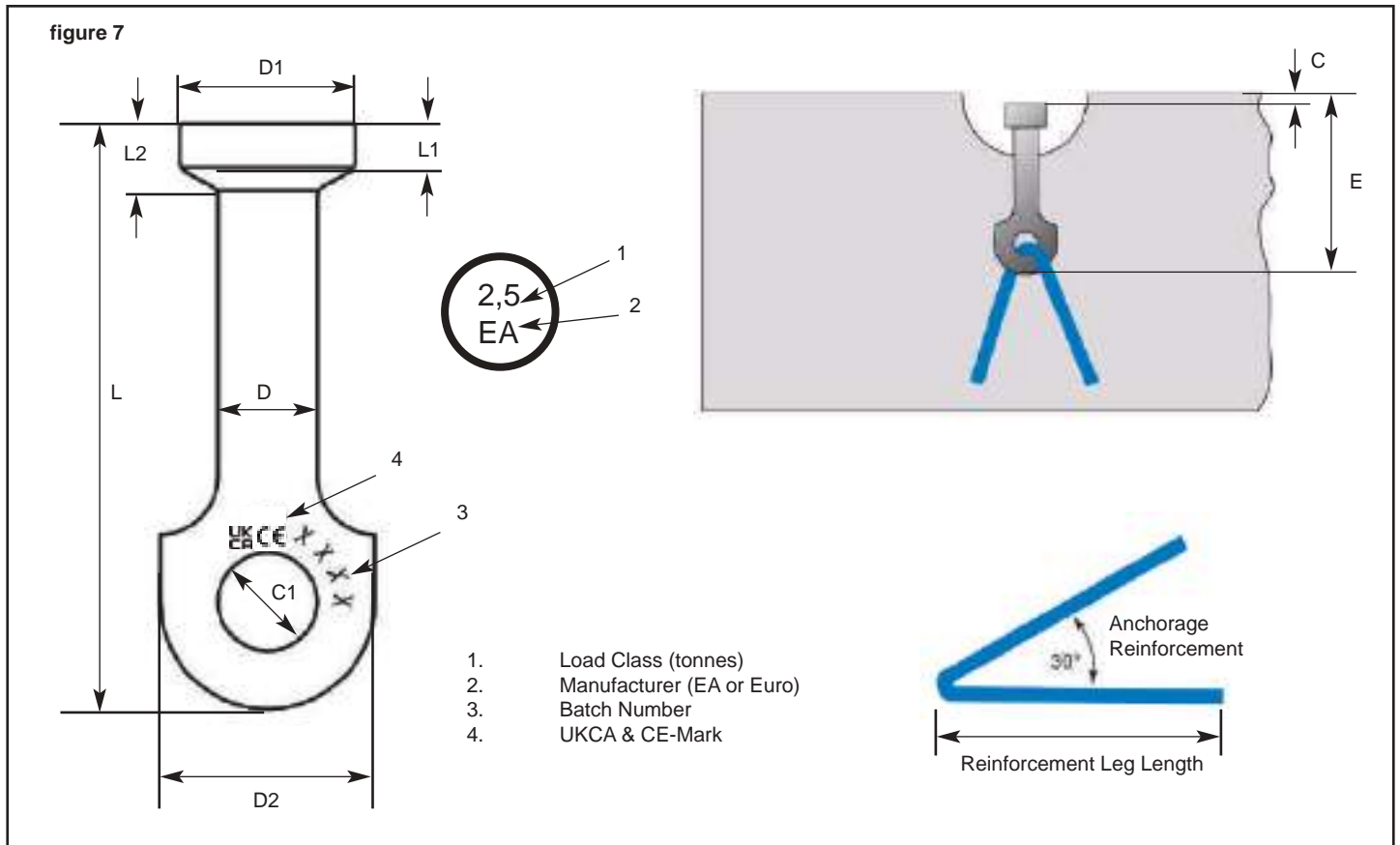

The Eye Anchor has been developed for instances where the standard Pin Anchors base cannot be utilised to transfer forces into the surrounding concrete. Used in conjunction with a reinforcement anchorage tail, lifting loads can be transferred deep into the concrete element. Consult table 17 and figure 7 for specific sizes and reinforcement anchorage details. This anchor must be used with the additional reinforcement specified. The reinforcement anchorage should be in contact with the anchor to prevent movement and damage to surrounding concrete.

table 17  
 Eye Anchor Dimensions

Load Capacity (tonnes)	Anchor Length L (mm)	D (mm)	D1 (mm)	D2 (mm)	L1 (mm)	L2 (mm)	C1 (mm)	C (mm)	Embedment E (mm)	Anchorage Dia. (mm)	Reinforcement Leg Length (mm)
1.3	65	10	18	19	5.0	8	10	10	75	8	450
2.5	90	14	25	27	7.0	10	13	11	101	10	600
5.0	120	20	36	42	8.5	13	20	15	135	16	900
10.0	115	28	46	57	12.0	18	25	15	130	20	1100
10.0	180	28	46	57	12.0	18	25	15	195	20	1100
20.0	250	38	69	76	14.5	27	37	15	265	32	1700

## Rod Anchors

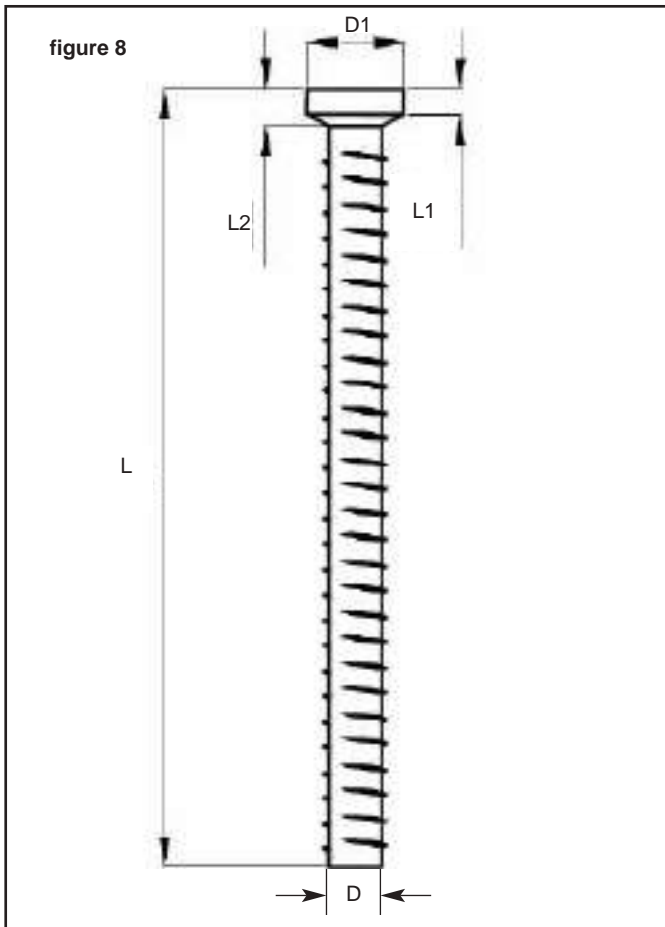

The Rod Anchor is manufactured from standard reinforcement steel yet maintains the head dimensions of the standard Pin Anchors and utilises the same formers and lifting clutches. Lifting loads are transferred into the surrounding concrete along the entire embedded length of the Rod Anchor. This makes the anchor ideal for use in very thin panels where concentrated loads can potentially damage the surrounding concrete. Minimum panel thicknesses must be observed when using the Rod Anchor. See table 18. Lifting with the Rod Anchor must not commence until the concrete compressive strength reaches 25 N/mm<sup>2</sup> with sling angles kept below 30° from vertical. If this criteria cannot be met consult our Technical department for assistance.

**table 18**  
Rod Anchor Dimensions

Load Capacity (tonnes)	Anchor Length L (mm)	D (mm)	D1 (mm)	L1 (mm)	L2 (mm)	Minimum Panel Thickness (mm)
2.5	400	14	25	7	10	90
2.5	520	14	25	7	10	90
5.0	580	20	36	9	13	120
5.0	790	20	36	9	13	120
5.0	900	20	36	9	13	120
7.5	750	24	46	11	18	140
7.5	1150	24	46	11	18	140
10.0	870	28	46	12	18	160
10.0	1300	28	46	12	18	160
15.0	1080	34	69	12	26	200
15.0	1550	34	69	12	26	200





## Curved Pin Anchors

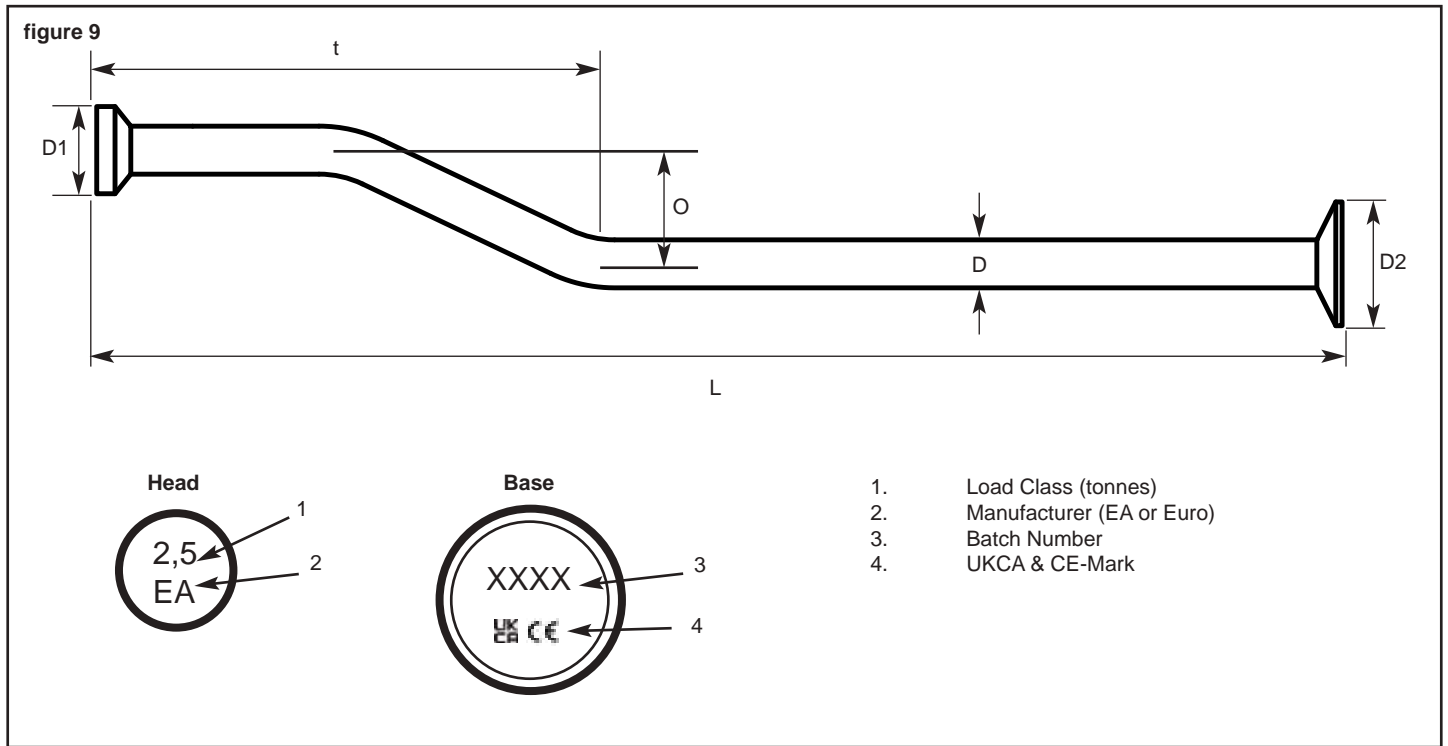

The curved pin anchor is primarily designed for the pitching, lifting and installation of energy efficient, insulated precast concrete sandwich panels. The offset relationship of the head and foot of the anchor allows placement within the heavier structural leaf of the panel, whilst bringing the lifting point close to or on the gravitational axis of the unit. This arrangement allows the panel to be lifted near to or in the vertical orientation. In addition to their primary role, these pins provide the facility for finite adjustment of the lifting points, where a lifting point on the longitudinal axis of a standard pin may not be ideal.

The selection of a suitably rated Curved Pin Anchor should follow the same procedures as a standard pin anchor, the overall dimensions of the available concrete should be checked to ensure the minimum requirements in the following sections can be adhered to. The following table 19 provides the overall dimension of the Curved Pin Anchor for each load group the offset dimension is given under dimension "o".

**table 19**  
Curved Pin Anchor Dimensions

Load Capacity (tonnes)	Anchor Length L (mm)	D (mm)	D1 (mm)	D2 (mm)	o (mm)	t (mm)
1.3	227	10	18	25	50	141
2.5	268	14	25	35	50	145
5.0	446	20	36	50	60	193
7.5	664	24	46	60	70	260
10.0	667	28	46	70	70	312
15.0	825	34	69	85	70	325
20.0	986	38	69	98	90	410

**Pitching of insulated panels:**

Providing the sandwich panels are manufactured or stored with the structural leaf uppermost, the curved anchor pin can be used to pitch the panels from horizontal to vertical. Panels cast with the outer architectural leaf uppermost should only be turned with a tilting table or by other means and must not be pitched to vertical using the Curved Pin Anchor. Where tilting facilities are available it is advisable that these should be adopted. Please observe minimum concrete strengths and concrete dimensions before attempting to pitch units with the Curved Pin Anchors.

**Slinging arrangements:**

The ideal method to pitch and lift sandwich panels with the Curved pin anchor is with the assistance of a tilting table and a spreader beam. However the anchors can be used to pitch units to vertical, ideally utilising a spreader beam as well. If any procedure is carried out using the Curved Pin Anchors maximum sling angles as per figures 13 & 14 and table 20 should be observed. Inclined sling angles greater than 30° from vertical are strictly forbidden with these anchors. There are further restrictions on sling angles based on the dimension of the preformed pocket in the structural element, figure 10 table 20 should be consulted to establish maximum sling angle arrangements based on pocket dimensions.

figure 10

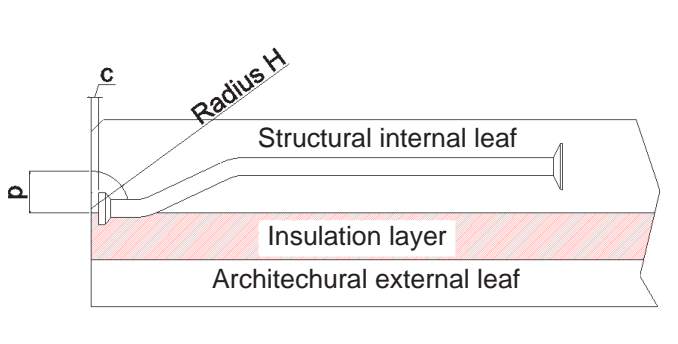
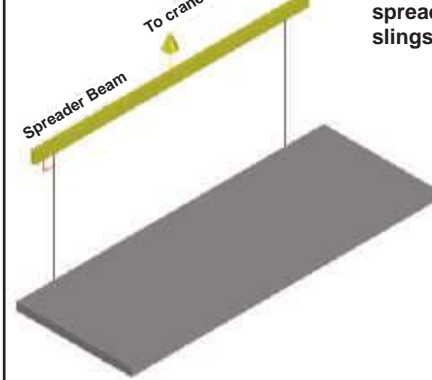

table 20  
Curved Pin Anchor Sling Angles  $\theta^\circ$

Load Capacity (tonnes)	H (mm)	c (mm)	$\theta = 0^\circ$	$\theta \leq 12.5^\circ$	$\theta \leq 30^\circ$
			$p \leq$ (mm)	$p <$ (mm)	$p \geq$ (mm)
1.3	30	10	30	36	36
2.5	37	11	37	44	44
5.0	47	15	47	56	56
7.5	60	15	60	72	72
10.0	60	15	60	72	72
15.0	80	15	80	96	96
20.0	80	15	80	96	96

figure 11



Pitching units with a spreader beam to bring slings to vertical.

figure 12

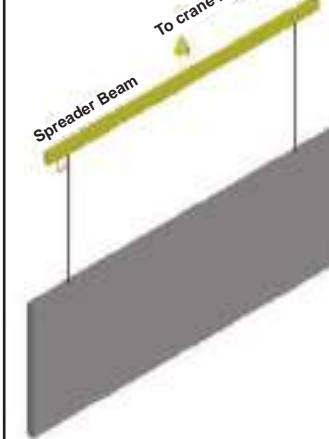

Vertical lift with spreader beam to bring slings to vertical.

figure 13

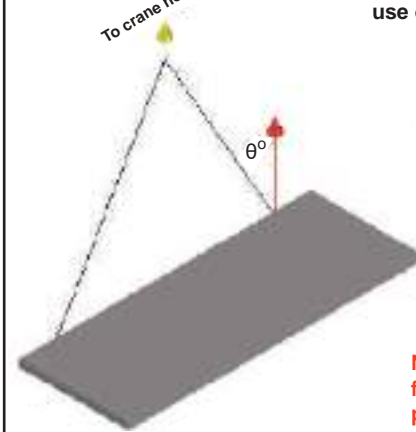

Pitching units without the use of a spreader beam.

Note  $\theta \leq 30^\circ$  (see table 20 for restrictions based on pocket size)

figure 14

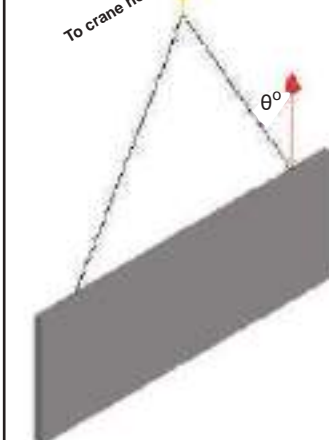

Lifting units without the use of a spreader beam.

Note  $\theta \leq 30^\circ$  (see table 20 for restrictions based on pocket size)



**Anchor Placements:**

The Curved Pin Anchor is subject to minimum edge distance, end spacing and anchor centres, these should be in accordance with figure 15 and table 21. Lifting and pitching procedures must not proceed until the concrete has achieved minimum compressive strengths set out in table 23.

**table 21**  
Curved Pin Anchor Placements

Load Capacity (tonnes)	Minimum dimensions		
	Ed (mm)	Es (mm)	As (mm)
1.3	40	130	260
2.5	50	185	370
	70		
5.0	50	410	820
	70		
7.5	60	605	1210
	75		
10.0	70	610	1220
	90		
15.0	90	750	1500
	110		
20.0	100	1015	2030
	125		

**figure 15** Minimum placements

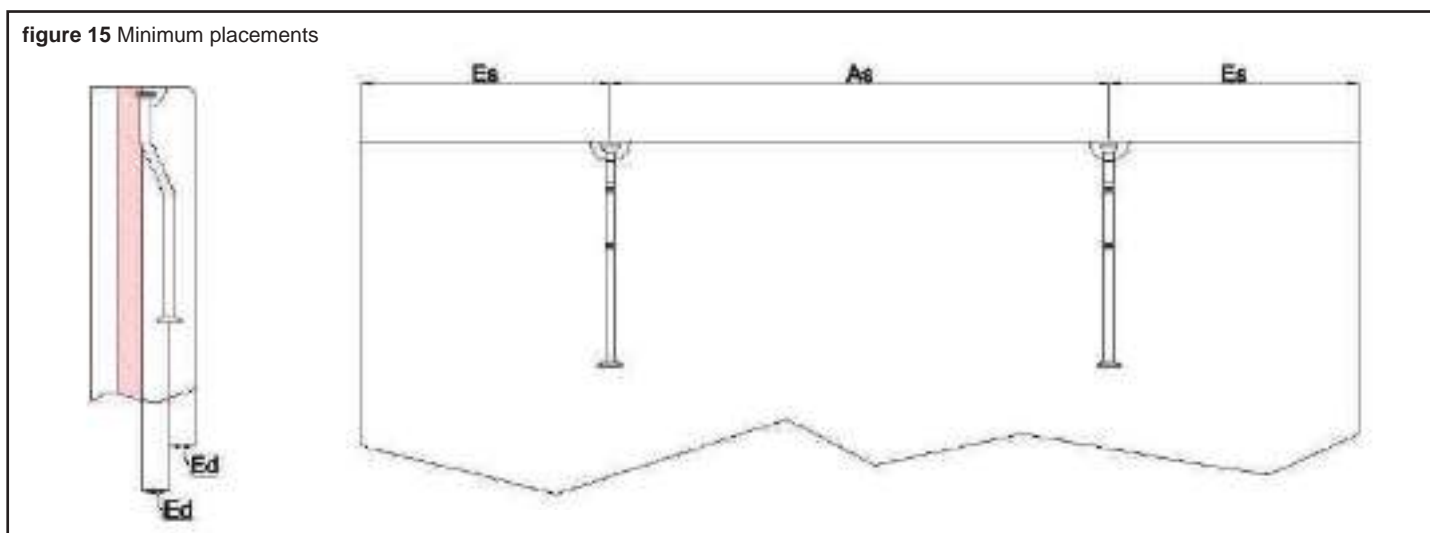

**Reinforcement:**

Whilst the curved pin anchor works on the same principals as the standard pin anchor, additional loads from the pitching process need to be catered for. Pitching and lifting of panels with the Curved Pin Anchor should only proceed if the additional anchor zone and surface reinforcement as per figure 16 and table 22 are correctly installed.

**table 22**  
Reinforcement

Load Capacity (tonnes)	Anchor zone B500B reinforcement dimensions				Minimum fabric each face to BS 8666
	Er dia (mm)	Sb dia (mm)	SI (mm)	Az (mm)	
1.3	10	6	400	230	A142
2.5	10	8	500	270	A142
5.0	10	8	750	450	A142
7.5	12	8	1000	665	A193
10.0	12	10	1000	670	A193
15.0	16	10	1000	825	A252
20.0	16	12	1100	990	A393

Bending of reinforcement should be in accordance with BS8666:2000

**figure 16**

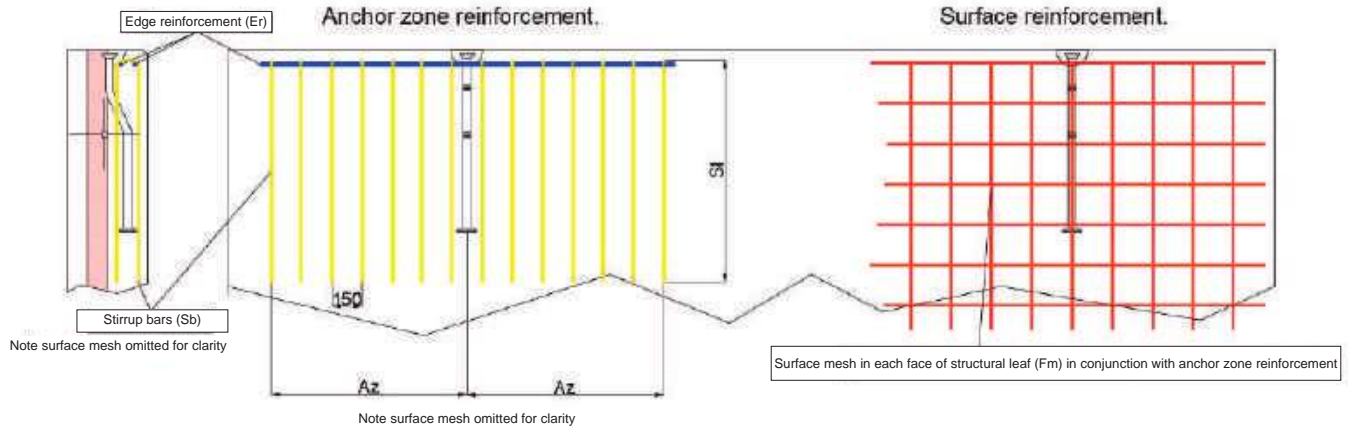

**Lifting Capacity at varying concrete strengths and edge distances.**

The ability of the Curved Pin Anchor to resist pull out forces in tension whilst lifting, and in shear whilst pitching varies with edge distance and concrete strength. After applying the minimum end spacing (Es) and anchor spacing (As) the following table 23 should be used to determine the ultimate loads for the anchors based on edge distance (Ed) and concrete strength (MPa).

**table 23**  
Curved Pin Anchor lifting capacity at varying concrete strengths and edge distances

Load Capacity (tonnes)	Ed (mm)	Maximum capacities (t) at varying concrete strength (Mpa)			
		15 ≤ MPa <25		25 ≤ MPa	
		Lifting	Pitching	Lifting	Pitching
1.3	40	1.30	0.65	1.30	0.65
2.5	50	1.59	0.95	2.03	1.22
	70	2.05	1.22	2.50	1.25
5.0	50	3.52	2.12	4.54	2.50
	70	4.53	2.50	5.00	2.50
7.5	60	5.09	3.05	6.58	3.75
	75	6.02	3.60	7.50	3.75
10.0	70	6.65	3.99	8.60	5.00
	90	8.03	4.82	10.00	5.00
15.0	90	10.32	6.19	13.30	7.50
	110	12.00	7.20	15.00	7.50
20.0	100	13.51	8.11	17.44	10.00
	125	15.97	9.59	20.00	10.00



## Pin Anchor Ring Clutches & Combination Ring Clutches

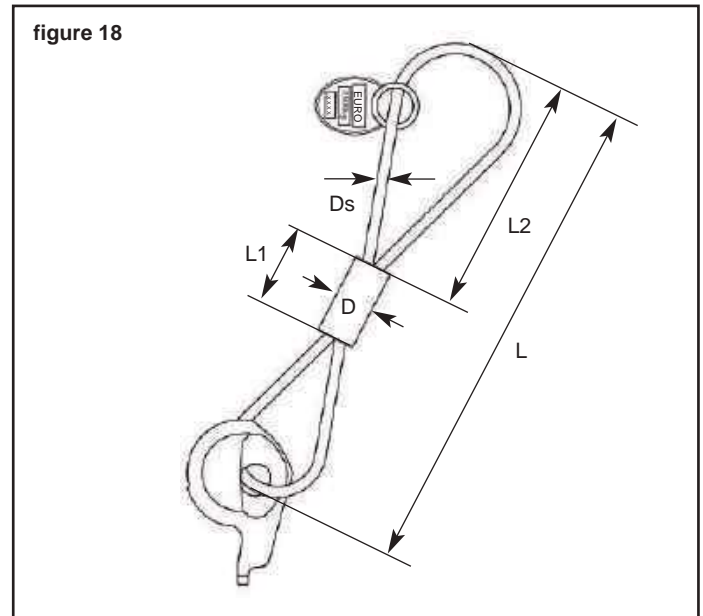
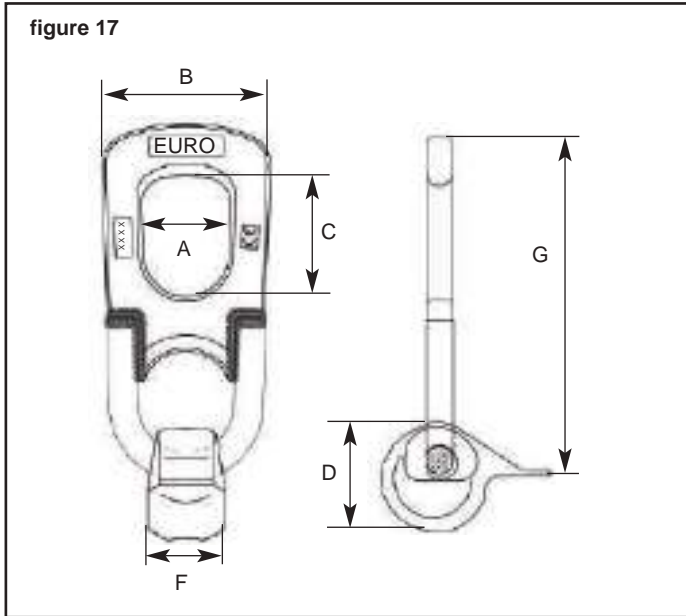

**table 24**  
Pin Anchor Ring Clutch Dimensions

Load Capacity (tonnes)	A (mm)	B (mm)	C (mm)	D (mm)	F (mm)	G (mm)
1.3	48	77	60	55	33	165
2.5	50	92	75	68	42	205
5.0	68	121	86	88	57	240
7.5 - 10.0	84	170	110	108	77	346
15.0 - 20.0	125	230	140	146	115	520
32.0	155	303	175	195	155	590

**table 25**  
Pin Anchor Combination Ring Clutch Dimensions

Load Capacity (tonnes)	L (mm)	L1 (mm)	L2 (mm)	D (mm)	Ds (mm)
1.3	320	60	150	17.0	8
2.5	560	105	250	28.0	14
5.0	690	155	300	37.5	18
10.0	1100	200	500	54.0	26

The Pin Anchor Ring Clutch is a robust lifting device manufactured from several cast components. The lifting clutch is designed to fit only the Pin Anchors and Recess Formers for the chosen load category. This in built safety feature, ensures that mismatching of load groups cannot occur.

The safe working load of the Pin Anchor Ring Clutch is based on a factor of 3 for safety. Each lifting clutch is stamped with a unique item number, it is supplied with a corresponding numbered test certificate verifying the item has been tested individually, to a proof load equal to twice the safe working load marked on the ring clutch.

The Combination Ring Clutch is similar in specification to the standard Pin Anchor Ring Clutch, but supplied with a wire rope lifting chain attachment. The wire rope offers greater flexibility when lifting elements with edges that may come into contact with the Ring Clutch chain attachment link. Minimising the potential cosmetic damage of the concrete.

### Routine Inspection and Retirement

Pin Anchor Ring Clutches & Combination Ring Clutches should be inspected before each use by a competent person. The inspection should involve a visual check for obvious defects, deformation of the oval ring or lifter body, cracks and obvious excessive wear. If any of these defects are found the lifting device should be discarded. If they are bent do not bend back into shape. Use of the Ring Clutch must not commence if any of the identification markings are worn away and no longer visible.

In addition the Ring Clutch & Combination Ring Clutch should be inspected and tested by a recognised organisation at least every twelve months.

# Accessories

## Pin Anchor Rubber Former

Load Capacity (tonnes)	R (mm)	A (mm)	B (mm)	C (mm)	D (mm)	H (mm)
1.3	30	9.5	10	10	66	32
2.5	37	14.0	11	14	80	39
5.0	47	15.0	15	20	100	48
7.5	60	15.0	15	24	128	61
10.0	60	15.0	15	28	128	61
15.0	80	19.0	15	38	170	80
20.0	80	19.0	15	40	170	80
32.0	108	22.0	17	50	236	107

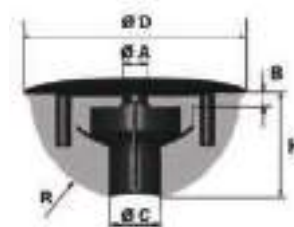

Use in conjunction with Pin Anchor Fixing Plate or Pin Anchor Mounting Plate.

## Magnetic Pin Anchor Rubber Former

Load Capacity (tonnes)	A (mm)	B (mm)	C (mm)	D (mm)	h (mm)	R (mm)
1.3	10	10	18.5	64	33.0	32
2.5	10	11	25.5	80	43.5	69
5.0	10	15	35.5	101	54.0	65
10.0	10	15	45.5	129	72.0	80

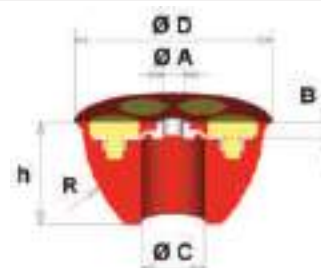

Use with Pin Anchor Rubber Ring.

## Pin Anchor Rubber Ring

Load Capacity (tonnes)	D (mm)	d (mm)	t (mm)
1.3	21	10	11
2.5	31	14	12
5.0	38	20	14
7.5	49	24	20
10.0	49	28	20

Used with Round and Magnetic Formers

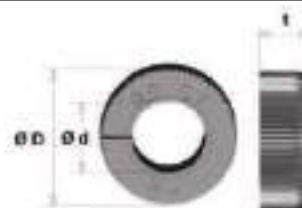

## Pin Anchor Fixing Plate

Load Capacity (tonnes)	Thread (M)	L (mm)
1.3	8	100
2.5	10	100
5.0	10	100
7.5 - 10.0	12	100
15.0 - 20.0	12	100
32.0	16	100

Used to Fix Rubber Formers to formwork.

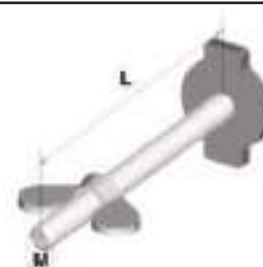

## Pin Anchor Mounting Plate

Load Capacity (tonnes)	D (mm)	L (mm)	H (mm)
1.3	66	38	17
2.5	80	50	20
5.0	100	60	26
7.5 - 10	128	80	31
15.0 - 20.0	170	110	39
32.0	236	128	54

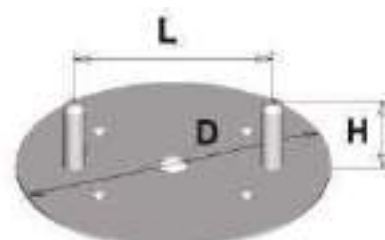

Allows Pin Anchor Rubber Formers to be fixed directly to the formwork face.



## Easy Lift Utility Anchors

The absence of any specialist lifting equipment, enables the Easy Lift Utility Anchor to be used to demould, turn, lift and place concrete elements in the production facility or on site with only the use of standard chains and hooks. Once the designer has determined the required lifting arrangements the precast manufacturer merely casts the anchors in a position that suits these pre-determined sling arrangements. Please refer to the following drawings for some typical applications. The formers should be placed to accommodate the angle of any slings and should be placed in such a manner that the hook does not make contact with any edges when lifting or turning units from one plane to another. The anchors can be utilised up to their maximum safe working loads provided the minimum panel thicknesses and anchor spacings are observed in table below. Please refer to pages 5,6 and 7 to calculate the actual load the anchors will be subject to.

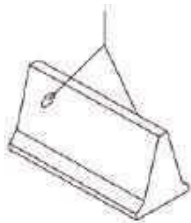

Barriers



Pipe

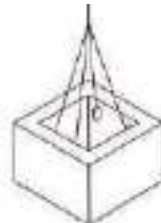

Boxes

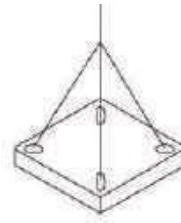

Slabs

Easy Lift Utility Anchor Dimensions

Product Code	Load Capacity (tonnes)	Length A (mm)	Width B (mm)	Rod Dia. F (mm)	Pin Head G (mm)
LAPU035095G	3.5	95	173	17	34
LAPU050120G	5.0	121	188	17	34
LAPU075170G	7.5	171	254	17	34

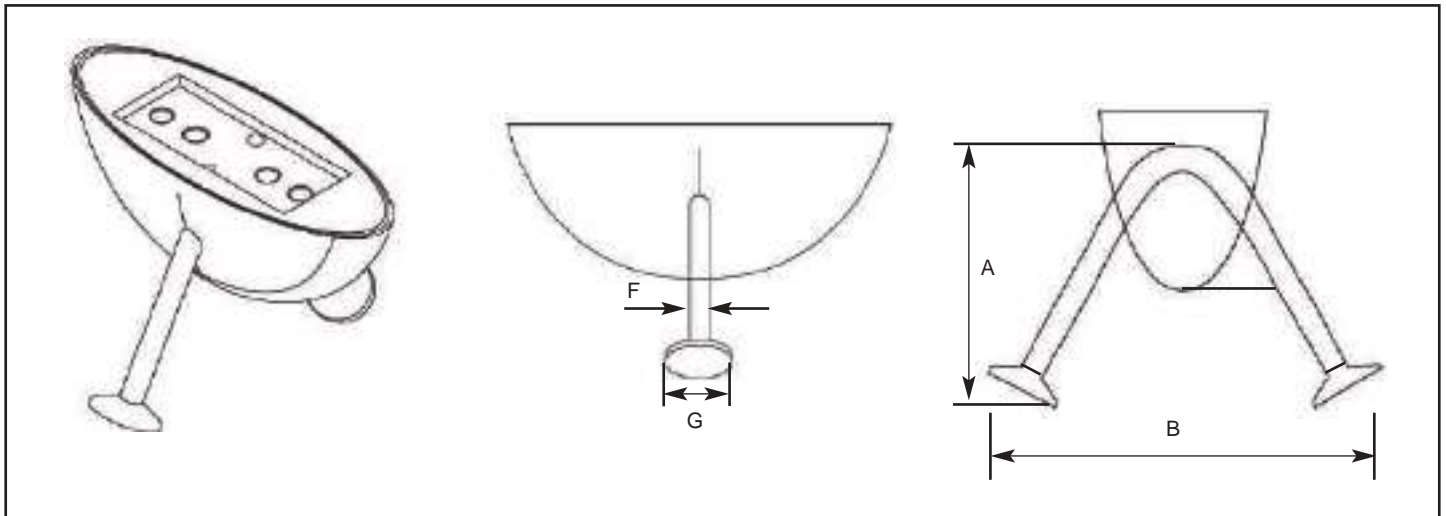

## Tension/Shear Working Load Limit

Load Capacity (tonnes)	Minimum Panel Width (mm)	Minimum Anchor Centres (mm)	Minimum Edge Distances (mm)	Maximum Lifting Capacity Varying Concrete Strengths (tonnes)					Maximum Capacity in Shear (tonnes) Minimum Concrete Strength 25N/mm <sup>2</sup>
				15 N/mm <sup>2</sup>	20 N/mm <sup>2</sup>	25 N/mm <sup>2</sup>	30 N/mm <sup>2</sup>	35 N/mm <sup>2</sup>	
3.5	115	570	190	2.4	2.9	3.2	3.3	3.5	3.2
5.0	140	720	240	3.3	4.1	4.5	4.7	4.9	4.5
7.5	205	1020	340	5.6	6.9	7.5	7.8	8.2	7.5

### Installation

There are several options for securing the anchors in the concrete prior to curing. These are as follows:

#### Exposed Surface Placement

Place the Easy Lift Utility Anchor into the corresponding Rubber Former and fix either the Wet Set Plate or the Steel Plate with threaded rod into the former via the two holes in the flat surface. Careful attention should be paid to sealing any gaps in the former with a suitable sealing tape. The whole assembly is pushed into the wet concrete until the flat edge of the former is flush with the concrete surface.

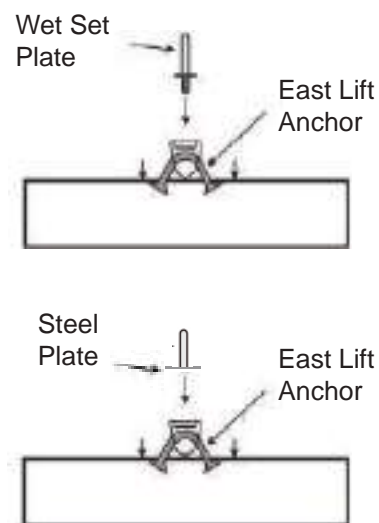

#### Fixing Inside the Formwork

To fix directly to the inside face of the formwork utilise the Reusable Mounting Plate. This is nailed, welded or glued to the formwork face. The two exposed pins fit snugly into the Rubber Former to hold and seal in place.

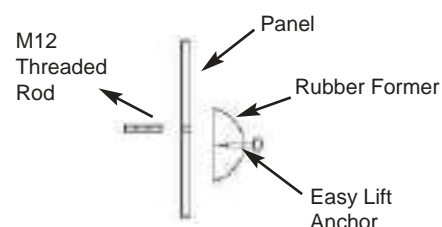

#### Fixing Through the Formwork

To fix through the formwork use M12 Threaded Rods which are finger tightened into the Rubber Former. The exposed thread is passed through a pre drilled hole in the formwork. The former is sealed and held securely in place using M12 wing nuts.

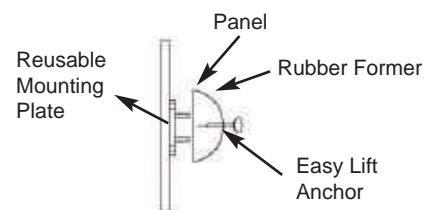



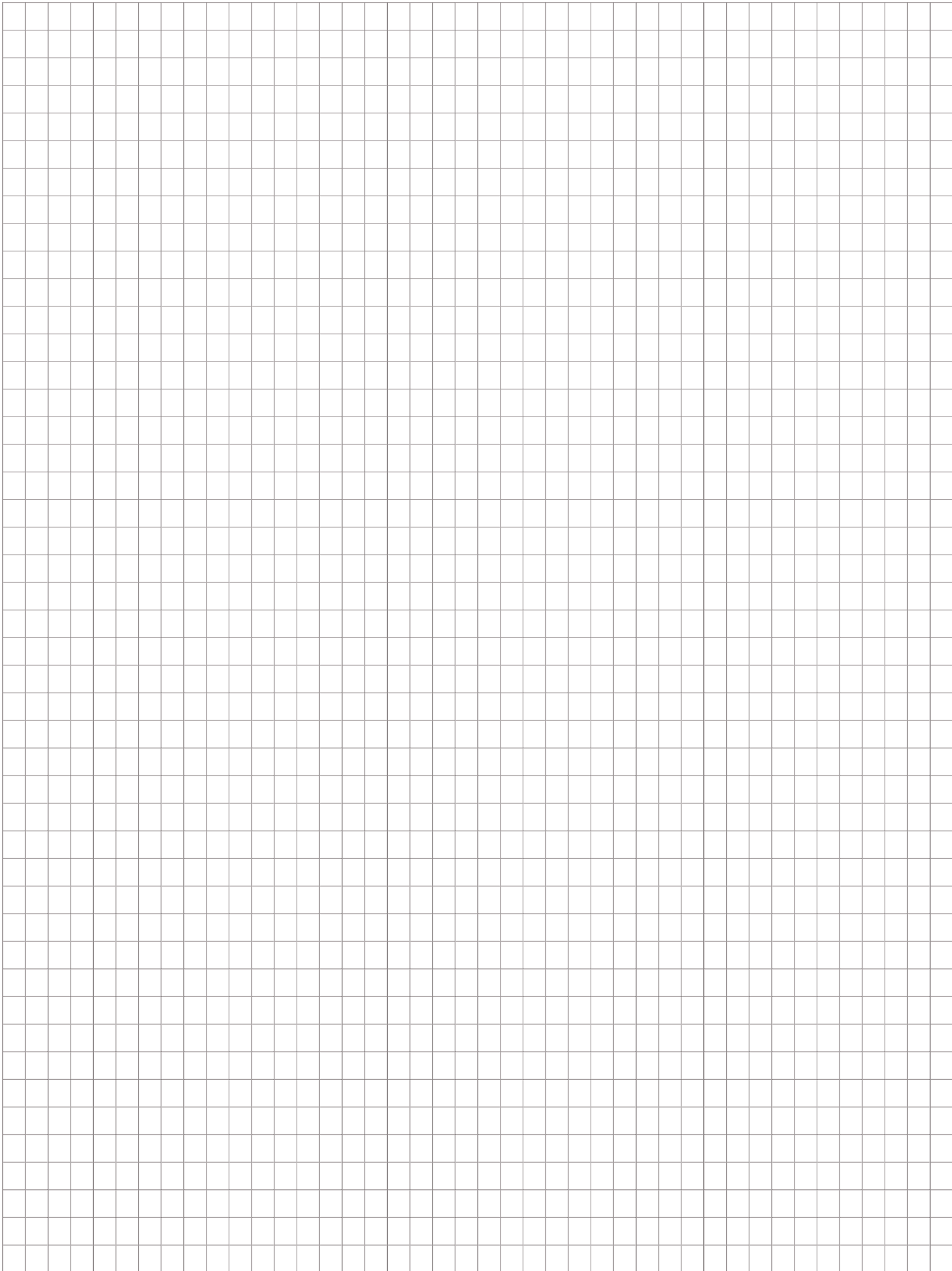

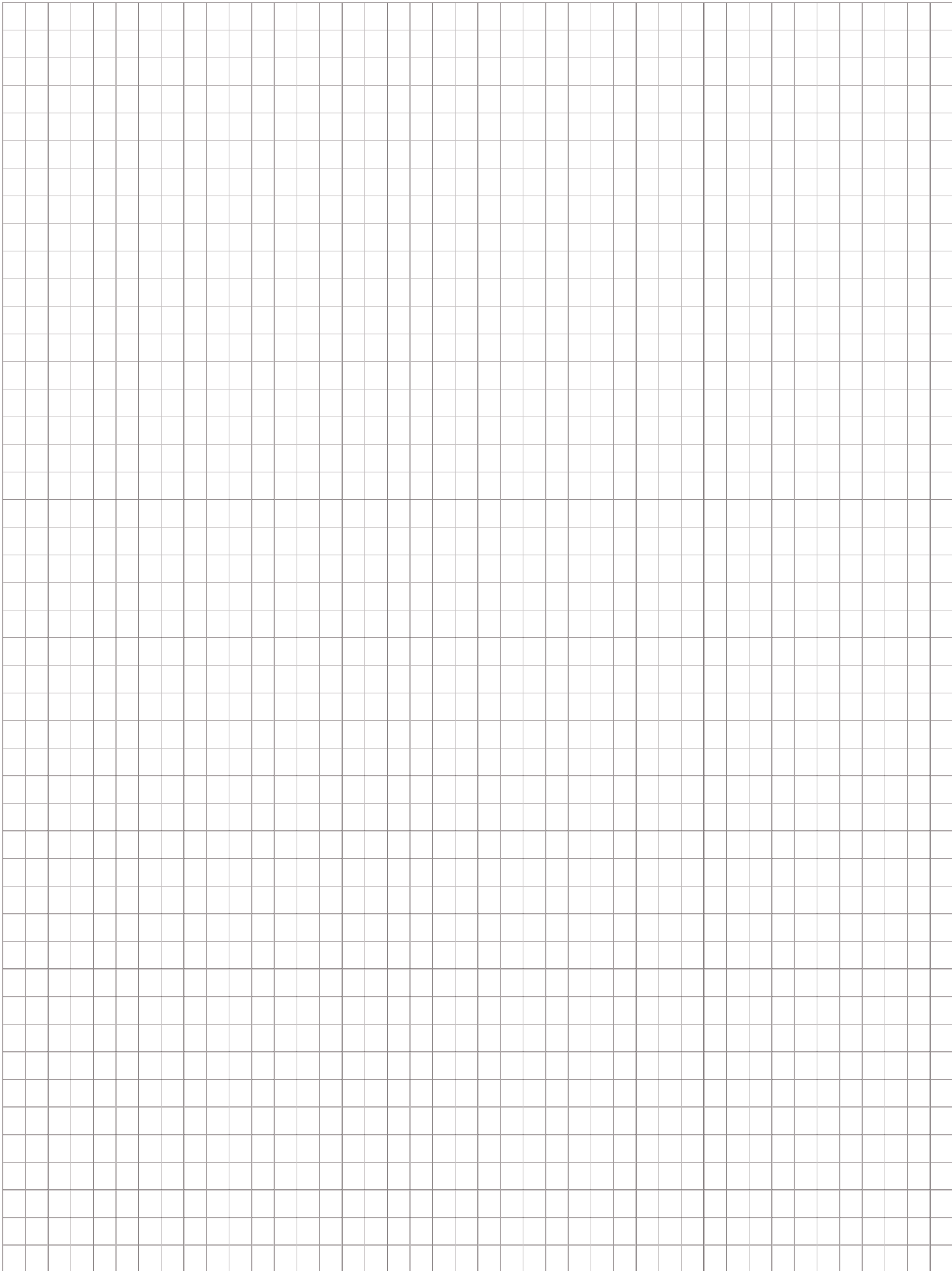

**Euro Accessories Ltd (Head Office)**

Units 1 - 3, Shannon Industrial Estate  
Lodge Road  
Sandbach  
Cheshire  
CW11 3HP  
t. 0044 (0) 1270 90 20 20  
e. info@euroacc.co.uk

**Euro Accessories Ltd (Southern)**

Unit 3, Stewart Road  
Kingsland Business Park  
Basingstoke  
Hampshire  
RG24 8NF  
t. 0044 (0) 1189 819 522  
e. basingstoke@euroacc.co.uk

**Euro Accessories Ltd (N.I.)**

12 Drumatee Road  
Markethill  
Co. Armagh  
BT60 1QE  
Northern Ireland  
t. 0044 (0) 28 3755 1397  
e. armagh@euroacc.co.uk

**Euro Accessories Ireland**

Strokestown Road  
Roosky  
Co. Roscommon  
N41 XW59  
Rep. of Ireland  
t. 00353 (0) 71 96 387 96  
e. sales@euroacc.ie

**BRITISH  
PRECAST****Euro Accessories Product Range:**

Plastic, Concrete & Wire Spacers

Slab Accessories

Magnet Systems

Cast-in Channel

Precast Accessories

Screed Rails

TJEP Rebar Systems

Reinforcement Continuity Systems

Formwork Systems & Accessories

Piling Accessories

Lifting & Fixing Systems

Double Walling Accessories

Chemicals & Sprayers

BAG Column Formers