



ST

Chain hoists
Original instructions

EN

Partner of Experts

STAHL
CraneSystems 

Contents

1	General information	5
1.1	Copyright	5
1.2	Symbols	5
1.3	Warranty	6
1.4	Declaration of conformity / declaration of incorporation	6
1.5	Spare parts	6
1.6	Terminology	6
1.7	Test book / crane logbook	7
1.8	Transport and storage	7
1.9	Weight	7
1.10	Installation, commissioning, maintenance and repairs	8
1.11	After-sales service	8
1.12	Periodic tests	8
1.13	Environmental information	9
	1.13.1 Life cycle assessment	9
	1.13.2 Energy consumption	9
2	Safety instructions	10
2.1	Use for intended purpose	10
2.2	Inappropriate use	10
2.3	Residual dangers	11
2.4	Organisational safety precautions	11
2.5	General regulations	12
2.6	Personal protective equipment	12
2.7	Protection against falling	12
2.8	Sound pressure level	12
2.9	Fire safety	12
2.10	Safety-conscious operation	13
2.11	Attaching load	13
3	Introduction	14
4	Installation	15
4.1	Stationary chain hoist	15
4.2	Chain hoist with trolley	16
	4.2.1 Assemble the trolley	16
	4.2.2 Adjust trolley to runway width	19
4.3	Installing trolley on chain hoist	21
4.4	Attach the trolley to the runway beam	23
4.5	Connecting electric trolley	24
4.6	Mounting guide rollers	24
4.7	Mounting support rollers	24
4.8	Runway end stop	25
4.9	Disassemble and assemble chain bucket	25
	4.9.1 Disassemble chain bucket	25
4.10	Mounting control pendant	27
4.11	Connecting to mains	27
	4.11.1 Protective conductor	27
5	Commissioning	28
6	Operating	29
6.1	Duties of crane operator	29
6.2	Operating control pendant	30
6.3	Emergency stop	30
7	Inspection and maintenance	31
7.1	Inspection intervals	32
	7.1.1 Every day	32
	7.1.2 Every month	32
	7.1.3 Every three months	32
	7.1.4 Every year	32
	7.1.5 Every five years	32
7.2	Checking function of slipping clutch without load	33

7.3	Adjusting slipping clutch - without load	33
7.4	Adjusting slipping clutch with test load.....	34
7.5	Hoist motor brake.....	35
	7.5.1 Checking brake.....	35
	7.5.2 Adjusting brake.....	35
	Replacing brake disc (brake rotor).....	37
7.6	Travel motor brake	38
7.7	Checking chains.....	38
	7.7.1 Check condition of the chain.....	38
	7.7.2 Check wear of the chains.....	38
7.8	Lubricate the chain.....	39
7.9	Replacing load chain.....	39
7.10	Replace the chain stopper	40
	7.10.1 Disassemble chain stopper	40
	7.10.2 Assemble chain stopper	40
7.11	Checking and mounting chain anchorage.....	42
7.12	Replace bottom hook block.....	42
	7.12.1 Disassemble bottom hook block.....	42
	7.12.2 Assemble new bottom hook block.....	43
7.13	Replacing two-fall bottom hook block.....	43
7.14	Replacing return sheave.....	43
7.15	Checking hook for wear.....	44
7.16	Oil change.....	44
7.17	Trolley.....	45
7.18	Operating hours counter	45
7.19	General overhaul	45
8	Wearing parts.....	46
8.1	Hoist	46
8.2	Trolley.....	47
8.3	Dismantling	47
8.4	Scrap disposal	47
9	Technical data.....	48
9.1	Conditions of use	48
9.2	Hoist	48
	9.2.1 Hoist motor data 50Hz	48
	9.2.2 Hoist motor data 60Hz	49
9.3	Specifications for mains connection.....	50
	9.3.1 Max. length of supply cable 50 Hz.....	50
	9.3.2 Max. length of supply cable 60Hz.....	51
9.4	Tightening torques for bolted connections	52
9.5	Lubricants.....	53
9.6	Lubricants for travel drive	53
9.7	Circuit diagrams	53
9.8	Chain certificate.....	54

1 General information

1 General information

You have purchased a STAHL CraneSystems product.
This product was constructed in accordance with the applicable European standards and regulations.

Read carefully and observe the operating instructions. Store the operating instructions within easy reach at the place of operation.

1.1 Copyright

Copyright STAHL CraneSystems GmbH, 2015. All rights reserved. Reproduction and copying, including excerpts, not permitted without written permission from the publisher. No liability for errors.

1.2 Symbols

In these instructions, the safety notices are classified according to the severity of the danger and the probability of its occurrence.

The procedures described for avoiding danger must be followed without fail.

DANGER

This symbol gives warning of an imminent danger to health and life.
Ignoring these warning notices will lead to severe injuries, possibly resulting in death.

WARNING

This symbol gives warning of situations that are potentially dangerous to health and life.
Ignoring these warning notices may lead to severe injuries, possibly resulting in death.

CAUTION

This symbol gives warning of situations, which are potentially dangerous to health.
Ignoring these warning notices may lead to injuries.

NOTICE

Warns of damage to property or the environment.

Specific symbols:



Warning of electrical voltage

Covers such as hoods and caps which are marked with this symbol may only be opened by "skilled or qualified personnel".
Contact with live parts can cause death instantaneously.



Warning of suspended load

It is forbidden for persons to stand under suspended loads.
This entails risks to life and limb!



Warning of injuries to hands

Danger of crushing or cutting hands and fingers. The appropriate personal protective equipment should be worn for this task to avoid injury.

1 General information



Tips / recommendations

Tips for use and other particularly important information.

1.3 Warranty

Observance of the operating instructions is essential for safe operation and achieving the stated product characteristics and performance features. Non-observance will lead to loss of warranty for the product and the machine in which the product is installed. In addition to the instructions given in the operating manual, all official and statutory regulations must be observed when operating the product. Use the product only for its intended purpose. Please note also the chapters "Technical data", "Use for intended purpose" and "Inappropriate use".

1.4 Declaration of conformity / declaration of incorporation

See separate document.

1.5 Spare parts

WARNING

Incorrect or defective spare parts may lead to damage, malfunctions or the complete failure of the machine.

- Only original spare parts must be used.

1.6 Terminology

User

Whoever uses and employs the product or has it operated by suitable trained personnel is considered to be the user (employer/company).

Trained personnel

Trained personnel are persons who have been instructed and trained in the duties with which they are entrusted and the risks which may arise from incorrect behaviour, have been advised on the necessary protective devices, precautions, applicable regulations, accident prevention regulations and prevailing conditions and have proven their ability.

Skilled electrician

A skilled electrician possesses knowledge and experience on electrical equipment arising from specialist training and, with knowledge of the applicable standards and regulations, is able to assess the work with which he is entrusted and detect and avoid possible risks. The skilled electrician must be familiar with the commissioning and operation of the product and have been trained on it.

Definition of a qualified person:

A qualified person is one who has gained the specialised knowledge required for testing the equipment from his/her vocational training, professional experience and recent professional activity.

This person must be in a position to assess the safety of the system in conjunction with the application. Qualified persons with the competence to undertake installation, commissioning, periodic tests, certain maintenance work and repairs on our products include the manufacturer's service engineers and trained fitters with the corresponding certification.

1 General information

1.7 Test book / crane logbook

A completed test logbook must be kept for each hoist. The results of the periodic tests must be entered in the logbook and certified by the test engineer.

1.8 Transport and storage

Transport

⚠ CAUTION

Danger of falling parts

- Use the marked sling points for transporting the hoist.
- The sling points are designed for a max. diagonal pull $\geq 45^\circ$, see Fig. 1.
- The product is delivered on a special pallet. This enables it to be loaded and unloaded safely with a fork-lift truck.
- If the product is to be transported suspended, it must be attached to the sling points provided.
- Do not allow the hoist to drop. The product must always be set down on the ground correctly.
- Avoid damage to the product and its components by loading and unloading it correctly.

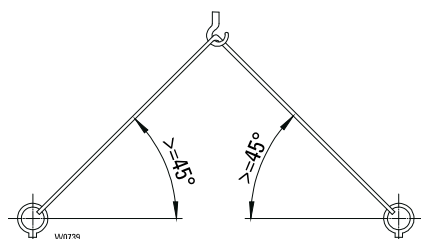

Fig. 1

Storage

- Store the product and its accessories in a dry place.
- Store it in a stable position, secure it against toppling or overturning.
- Observe environmental protection laws for storage (do not allow oil etc. to leak).
- The ground must be firm and must not permit the machine to sink in.
- Ensure the load is evenly distributed, support the hoist at several points.
- Do not kink the ropes and avoid contact with the ground.

1.9 Weight

See factory certificate.

1 General information

1.10 Installation, commissioning, maintenance and repairs

- Installation, commissioning, maintenance and repairs may be carried out by qualified persons only.
- We recommend having installation carried out by qualified personnel engaged by the manufacturer.
- Do not carry out any alterations or modifications.
- Additional fitments must be approved by the manufacturer.
(During welding work, electrode and ground must be in contact with the same component!)
- Use only original spare parts for repairs.
- Dismantled guards must be screwed down again and locked.

If the chain hoist is constantly operated out of doors and exposed to the elements without protection, we recommend fitting a canopy or at least "parking" the hoist under a roof.

1.11 After-sales service

You have purchased a high-quality product. A contracted after sales service will give you advice on its maintenance and correct use.

In order to maintain the safety and constant availability of the product, we recommend concluding a maintenance agreement.

1.12 Periodic tests

Hoists and cranes must be inspected by a qualified person (see chapter 1.6) at least once a year, more frequently if so specified by national regulations.

The results of the test must be recorded and filed in the test logbook.

The remaining service life of the hoist acc. to FEM 9.755 must also be established during this inspection.

The periodic tests must be adapted to the hoist's use. Intensive use or adverse environmental conditions entail shorter maintenance intervals.

All tests must always be initiated by the user! (see chap.1.6)

1 General information

1.13 Environmental information

Environmental aspects have been taken into account when developing and manufacturing this equipment. Please note the instructions on safe lubrication and waste disposal to avoid pollution risks during use. Appropriate use and correct maintenance will improve the environmental performance of this product.

1.13.1 Life cycle assessment

The stages of the product service life are:

- Production of materials,
- components and energy,
- transport to factory,
- manufacture and assembly,
- transport to customer,
- on-site installation,
- operating phase including maintenance and modernisation,
- dismantling and recycling of materials at end of service life.

1.13.2 Energy consumption

The energy consumption during the operating phase has the highest impact on the environment. Electricity is required for starting and running the motors and for lighting, heating, cooling and other optional electrical components and parts of the hoist.

2 Safety instructions

2 Safety instructions

2.1 Use for intended purpose

- Chain hoists are intended for lifting freely movable loads. Depending on their design, they are for stationary or mobile use.
- Chain hoists for "guided loads" have to be specially designed for this type of application. Pulling/towing or raising/lowering of a guided load is then only permitted if the chain hoist or system is designed for that purpose.
- Runways, suspensions and end stops must be of suitable dimensions.
- Any fundamental alterations and modifications to the product, such as e.g. welding on load-bearing components, structural alterations to load-bearing components, alteration of drives, alteration of speeds and motor outputs, replacing trolleys, etc. must be authorised by the manufacturer, otherwise the declaration of conformity/declaration of incorporation will be invalidated.
- Also any work on or additions to the control must be authorised by the manufacturer. The manufacturer cannot accept any liability for malfunctioning after unauthorised work on the control.
- Load hoist only up to the maximum working load, following the data on the rating plate. (Caution: danger of load falling).
- The conditions in the place of use of the hoist must correspond to the operating conditions for which the hoist was designed (including indoor/outdoor use, ambient temperature, radiation temperature, wind, dust, splash water, snow, water, etc.
- For hoists which work in combination and have more than one control (tandem operation), action must be taken to coordinate the controls. This applies also to the reaction of the protective devices.
- For hoists intended for automatic operation, the control must be designed accordingly
- In the case of chain hoists with multiple load-bearing equipment, ensure that the load is distributed evenly between the falls. Any asymmetry arising must not exceed the maximum load stated on the corresponding load capacity plate.

2.2 Inappropriate use

- Use in areas with potentially explosive atmosphere.
- Transporting molten metal.
- Exceeding the maximum working load.
- Transporting persons.
- Use of the hoist in applications where the load during a lifting procedure may exceed the maximum load-bearing capacity (e.g. single-sided attachment of long items), if no additional overload safeguard is present.
- Pulling loads loose, pulling or towing loads
- Pulling loads at an angle, dragging loads or moving vehicles with the load or load suspension equipment
- Do not knot load ropes or chains or shorten them with devices such as bolts, screws or similar
- Removing the safety latch from suspension and load hooks is not permitted
- Manipulating the slipping clutch
- Operating the hoist with slack chain
- Touching the chain during the hoisting motion
- Operating a damaged hoist
- Operating the hoist with the chain twisted
- Approaching the emergency limit switch in normal operation
- Approaching top and bottom hook position (slipping clutch) in normal operation.
- Manipulating the overload safety device.

2 Safety instructions

- Operating the chain hoist without a phase monitoring relay if a control supplied by the customer is not installed in an electrical connection box on the chain hoist, but e.g. in a stationary control cabinet.
- If the product forms "part of a machine," the person placing it on the market must ensure that the product meets the specific regulations of the application.
- Application of external torques due to forces that are exercised from outside the system, e.g. with gripper operation or through tilting/bumping of the load, in particular with the option 4×90° hook locking.

2.3 Residual dangers

The machine has been subjected to a risk analysis. The design and construction based on this correspond to the state of the art. However, residual hazards remain during operation and maintenance and these could result in serious or even fatal injuries to personnel.

- Risk of crushing
- Hazard due to falling parts (attached to the load or on the load)
- Load toppling due to unsuitable or damaged load-bearing equipment
- Risk of electric shock

Preventative measures:

- The machine functions with high voltage.
- Switch the machine off and ensure it cannot be switched on again before carrying out maintenance, cleaning and repair work.
- Switch off the power supply before all work on the electrical system. Check that the components to be replaced are free of current and voltage.
- Do not remove any safety devices or override them by manipulating them.
- When lifting or lowering loads ensure that no-one is in the immediate danger area.
- It is forbidden for anyone to stand in the danger area.

2.4 Organisational safety precautions

- The user may only employ persons to operate the product independently (crane operator), install or maintain the product if they
 1. have reached the age of 18,
 2. are capable both physically and mentally,
 3. have been instructed in operating and maintaining the crane and have shown him proof of their competence and
 4. may be expected to perform the duties assigned them reliably.
- At regular intervals, check that work is being carried out in a safety-conscious manner.
- Observe the intervals specified for periodic tests. File the test reports in the test log-book.

2 Safety instructions

2.5 General regulations

- Safety and accident prevention regulations.
- Official and statutory regulations.
- National regulations.

2.6 Personal protective equipment



Fig. 2

Personal protective equipment to be provided by the user

- Safety shoes
- Gloves (only if there is no danger of them being drawn into equipment)
- Protective goggles
- Protective helmet
- Hearing protection
- Closely fitting clothes (danger of clothing being drawn into equipment)
- When operating hoist or standing close to hoist, wire rope or chain there is a danger of fingers, clothing, jewellery, etc. being drawn into equipment

2.7 Protection against falling

Work over 2 m above the ground may only be performed from work platforms. Fitters working outside work platforms must be secured with a fall protection system.

2.8 Sound pressure level

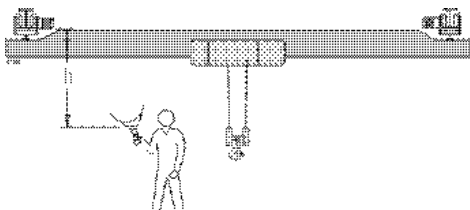

Fig. 3

The sound pressure level was measured at a distance of 1 m from the chain hoist. The mean sound pressure level is calculated for one operating cycle (50 % with maximum permissible load, 50 % without load).

Type	[dB A]
ST 05	76
ST 10 - ST 60	74

2.9 Fire safety

⚠ WARNING

Never use a powder extinguisher in the presence of high voltages

Only fight the fire if this is possible without subjecting yourself to risk. Switch off the crane if this is possible. Evacuate the area. Advise other persons on potential danger and call for help.

2 Safety instructions

2.10 Safety-conscious operation

- ST chain hoists are constructed according to the state of the art and equipped with a slipping clutch as overload protection. In spite of this, dangers may arise from inappropriate use or use for an unintended purpose.
- The user is responsible for ensuring that work is carried out with safety in mind and avoiding risks, see chap. 1.6.
- Read the instructions before starting to work with the product.
- Standing under a suspended load is forbidden. Danger to life and limb!
- Observe the "Duties of crane operator".
- Before starting work, find out where the emergency stop button is (usually in the control pendant).
- Do not put your hand between edges that might crush or cut.
- Do not grasp the moving chain.
- Take note of the relevant instructions when attaching loads.
- Do not stand between load and wall.
- Start lifting the load carefully.
- Never attempt to remedy a malfunction while the load is suspended.
- Never use bent, open or distorted load hooks, or attempt to straighten them.
- Have a damaged hook latch repaired.
- Never anneal the hook.
- Never lock the buttons of the control switch in place.
- Never allow the load to drop into the hoist's load-bearing equipment.
- Before lifting loads, ensure that the stated maximum working load is not exceeded.
- When lifting and setting down loads, ensure that they are in a stable position in order to avoid accidents due to the load toppling or overturning.
- Secure the load if the power is cut.
- Have a damaged hook safety latch repaired.
- Do not kink or crush control cables.
- Choose a safe place from which to operate the hoist.
- Joining or mending ropes, chains or belts is not permitted.
- Never touch metal components that are colder than 0°C or hotter than 55°C without wearing protective gloves.
- Report damage and defects to the product (abnormal noises, impaired braking function, deformations, ...) to the person responsible immediately. Do not use the product until the faults have been eliminated.
- Do not remove information plates from the product. Replace illegible or damaged plates.
- Never expose control cables to tensile stress. It is strictly forbidden to move the hoist by pulling on the control pendant.
- Have hoist inspected by the relevant authority before commissioning.

2.11 Attaching load

- Use only tested and approved slings for attaching the load.
- The rope must not be wound around the load.
- The load must always be suspended from the base of the hook. The tip of the hook must not be subjected to load.
- Removing the safety latch from suspension and load hooks is not permitted.

3 Introduction

3 Introduction

Chain hoists are intended for lifting freely movable loads.

The modular system permits a multitude of combinations of the components.

The hoist drive is a cylindrical rotor motor with a separately activated D.C. brake. Its design complies with the FEM calculation regulations which are adapted to the requirements of hoist operation.

Our certified quality assurance system to ISO 9001 guarantees consistently high quality.

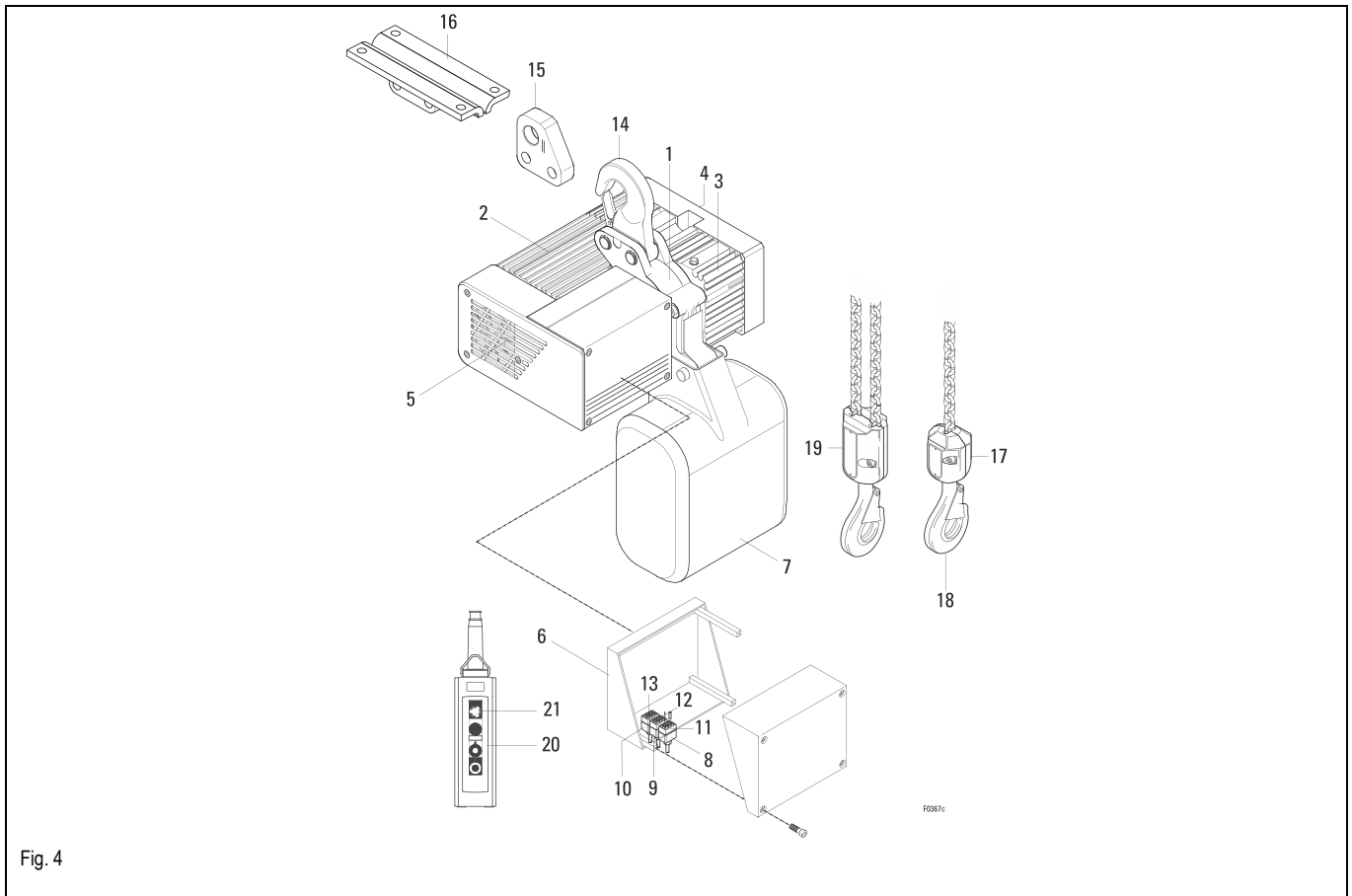

- | | |
|-------------------------------|----------------------------------|
| 1 Chain drive | 12 Socket for travel drive |
| 2 Motor | 13 Socket for mains connection |
| 3 Gear | 14 Suspension hook |
| 4 Slipping clutch | 15 Suspension eye |
| 5 Brake | 16 Rigid suspension |
| 6 Panel box | 17 Single-fall bottom hook block |
| 7 Chain box | 18 Load hook |
| 8 Plug for control pendant | 19 Two-fall bottom hook block |
| 9 Plug for travel drive | 20 Control pendant |
| 10 Plug for mains connection | 21 Emergency stop |
| 11 Socket for control pendant | |

4 Installation

4 Installation

4.1 Stationary chain hoist

▲ WARNING



Danger due to falling parts

- Check correct assembly of the overhead suspension prior to commissioning.

ST 05

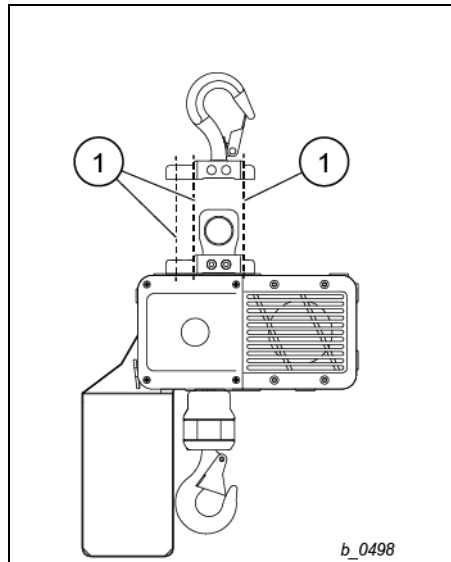

ST 10 - ST 60

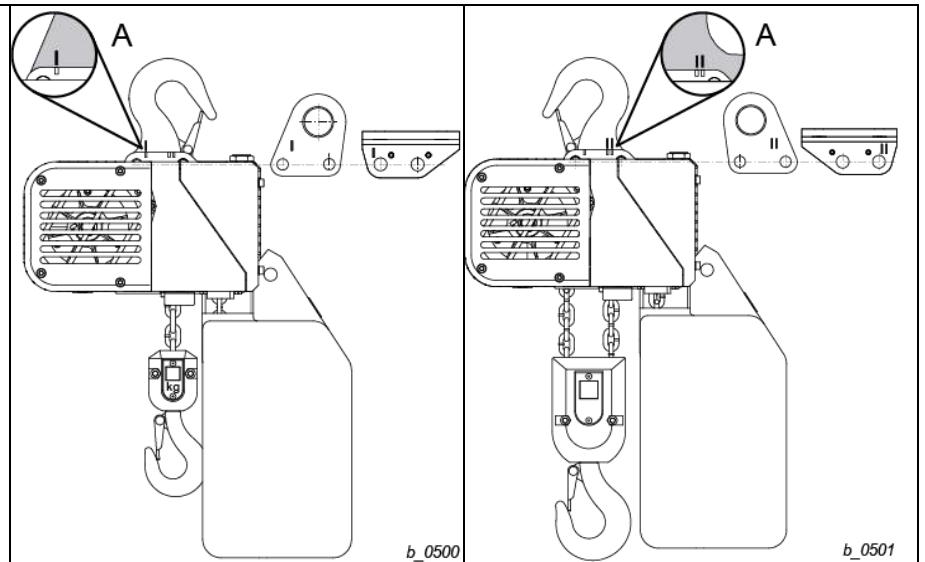

Fig. 5

Fig. 6

- (1) Threaded connection of the overhead suspension
Tightening torque of the screws (1) 15 Nm.

For the assembly procedure please refer to the chapter **Assemble trolley on chain hoist**.

4 Installation

4.2 Chain hoist with trolley

4.2.1 Assemble the trolley

US-G10

- (1) Trolley side cheek
- (2) Snap ring
- (3) Suspension bolt
- (4) Washer
- (5) Distance washers
- (6) Castellated nut

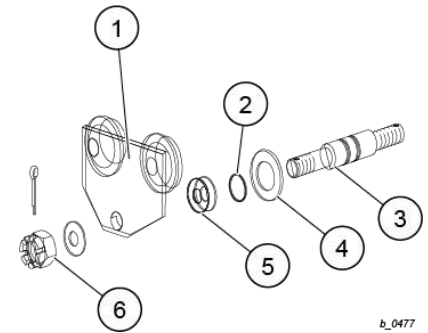
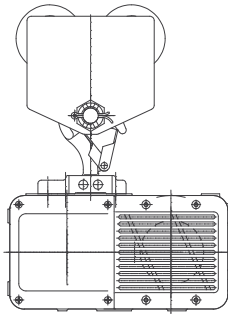

b_0477

Fig. 7

1. Fit the overhead suspension (if available) on the suspension bolt (3).
2. Fit the washer (4) on the suspension bolt (3).
3. Attach the snap ring (2) to the suspension bolt (3).
4. Set the correct dimension through the symmetrical distribution of the distance washers (5).
5. Fit the trolley side cheek (1) on the suspension bolt (3).
6. Screw on castellated nut (6) with distance washers (5).
7. Repeat steps 2 to 6 with the second side.
8. Adjust runway width with adjusting washers (see chapter Adjust trolley to runway width).
- Overhead suspension must be central to the trolley.
9. Tighten castellated nut and then release to the next cotter pin hole.
10. Attach screw locks.

4 Installation

KFN 10 / 63

KFK 10 / 63

- (1) Screw lock
- (2) Nut
- (3) Distance washer
- (4) Snap ring
- (5) Washer
- (6) Overhead suspension
- (7) Trolley side cheek

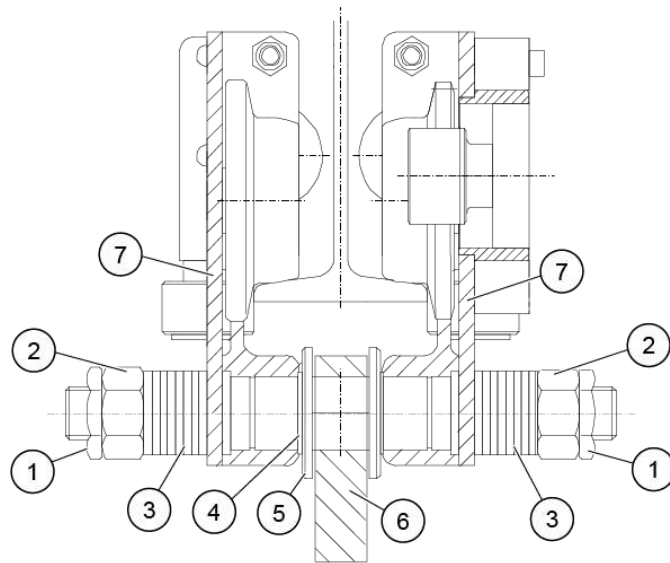

b_0478

Fig. 8

1. Fit the overhead suspension (6) on the suspension bolt.
2. Fit the washer (5) on the suspension bolt.
3. Attach the snap ring (4) to the suspension bolt.
4. Set the correct dimension through the symmetrical distribution of the distance washers (3).
5. Fit the trolley side cheek (7) on the suspension bolt.
6. Screw the nut (2) with the distance washers (3).
7. Repeat steps 2 to 6 with the second side.
8. Adjust runway width with adjusting washers (see chapter Adjust trolley to runway width).
- Overhead suspension must be central to the trolley.
9. Tighten the nut (2) with the specified torque (see table).
10. Attach screw locks (1).

Type	Nm
KFN 10 / KFK 10	130
KFN 63 / KFK 63	1100

4 Installation

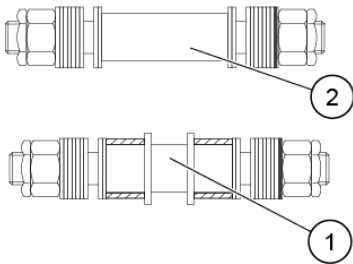
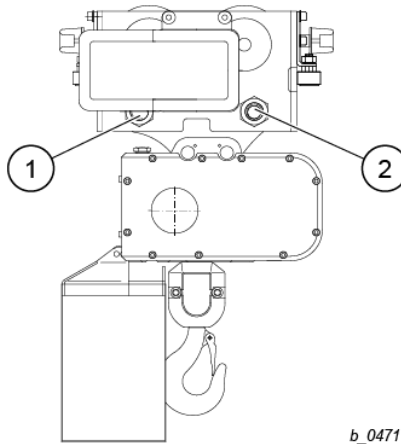

Fig. 9

- (1) Suspension bolt with spacer sleeves
- (2) Suspension bolt

b_0472

KFN 32



KFK 32

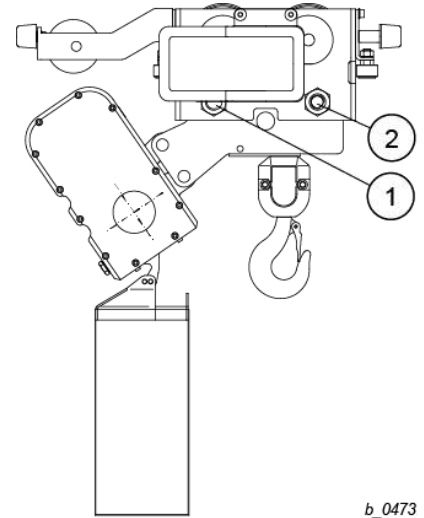

Fig. 10

b_0471

b_0473

1. Insert the suspension bolt in the overhead suspension.
Insert the suspension bolt (1) in position (1) with spacer sleeves.
 - Set the correct dimension through the symmetrical distribution of the distance washers and spacer sleeves.Insert the suspension bolt (2) in position (2) without spacer sleeves.
 - Set the correct dimension through the symmetrical distribution of the distance washers.
2. Fit the trolley side cheeks on the suspension bolts.
3. Adjust runway width with adjusting washers (see chapter Adjust trolley to runway width).
 - Overhead suspension must be central to the trolley.
4. Tighten the nut with the specified torque (470 Nm).
5. Attach screw locks.

K.T 22

- (1) Hexagon head screw
- (2) Nut
- (3) Distance washer 3 mm
- (4) Distance washer 1 mm
- (5) Trolley side cheek
- B Runway width
- a Track clearance

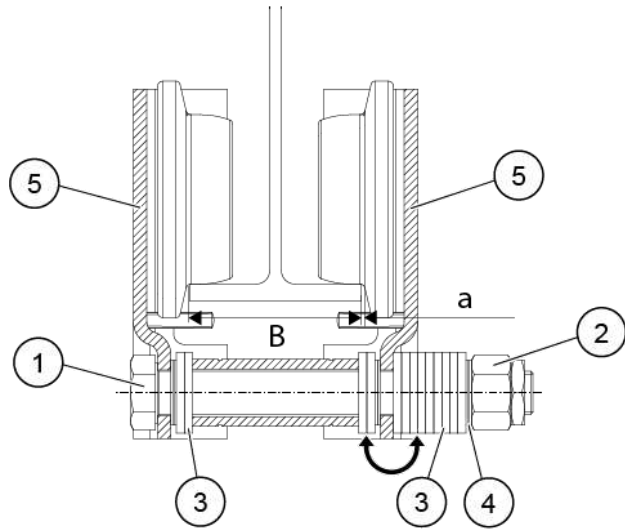

b_0499

Fig. 11

1. Fit the first trolley side cheek (5) on the hexagon head screw (1).
2. Set the correct dimension through the symmetrical distribution of the distance washers (3, 4).
3. Fit the second trolley side cheek (5) on the hexagon head screw (1).
4. Adjust runway width with adjusting washers (see chapter Adjust trolley to runway width).
5. Screw the nut (2) with the distance washers (3, 4).
 - Overhead suspension must be central to the trolley.
6. Tighten the nut (2) with the specified torque (52 Nm).
7. Attach screw locks.

4.2.2 Adjust trolley to runway width

⚠ WARNING



Danger due to falling parts

The chain hoist must not be operated without screw locks.

Check correct assembly of the overhead suspension prior to commissioning.



- If the runway width deviates from the dimension specified in the order, clarify with the manufacturer whether the trolley supplied is suitable for the actual runway width.
- Always hang the chain hoist in the centre of the trolley.
- Lubricate the teeth of the running rollers with grease.
- Only perform runway width adjustments with original parts.

4 Installation

- A Track clearance
 B Runway width
- (1) Screw lock
 (2) Nut
 (3) Distance washer 3 mm
 (4) Distance washer 1 mm
 (5) Trolley side cheek

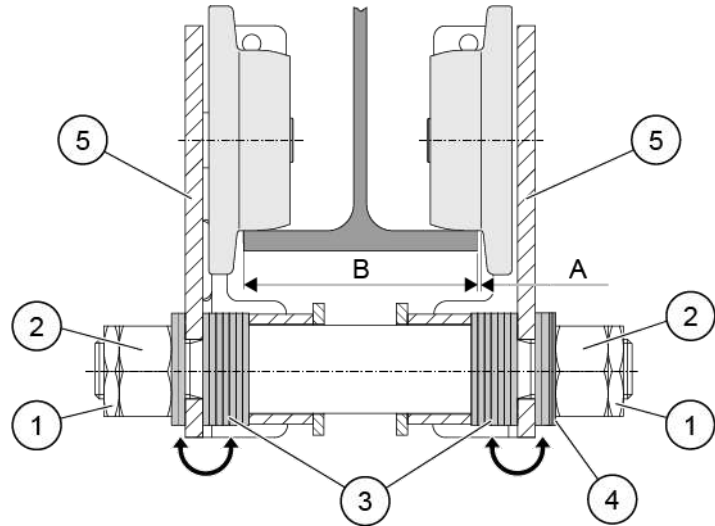

b_0479

Fig. 12

The trolley is set to the runway width (B) specified in the order. The track clearance (a) per side is 3 mm. If necessary, the track clearance (a) can be readjusted by moving the distance washers (3) and (4) as described in the following. The track clearance (a) must not be greater than 3 mm on one side.

▲ WARNING



Danger due to falling parts

An unsecured chain hoist can cause falls and injuries.

➤ Secure chain hoist against falling.

1. Secure chain hoist against falling.
2. Remove screw lock (1).
3. Loosen the nut (2).
4. Remove the trolley side cheek (5) from the suspension bolt.
5. Set the correct dimension through the symmetrical arrangement of the distance washers (3) and (4).
6. Fit the trolley side cheek (5) on the suspension bolt.
7. Tighten the nut (2) with the specified torque (see table).
8. Attach screw locks (1).

Type	Nm
US-G10	Tighten castellated nut and then release to the next cotter pin hole.
K.T 22	52
KFN 10 KFK 10	130
KFN 32 KFK 32	470
KFN 63 KFK 63	1100

4 Installation

4.3 Installing trolley on chain hoist

⚠ WARNING



Danger from falling parts

There is a danger that an unsecured bolt may become loose and the hoist fall.

➤ Always secure the bolt.

1. US-G 10 with ST05

Always suspend chain hoist from centre of trolley. See sketch, page 15

US-G 10 with ST10

Fit suspension piece to chain hoist. Note installation position of suspension piece. Fit bolt (a) and locking plate (b), lock cheese-head screw (c) with medium-strength thread locker (e.g. Loctite 245), see sketch.

KFN 10/32 with ST10/ST20-ST32; ST50 /ST60 1/1 - KFN 63 with ST50 / ST60 2/1

Fit suspension piece to chain hoist. Note installation position of suspension piece. Fit bolt (a) and locking plate (b), lock cheese-head screw (c) with medium-strength thread locker (e.g. Loctite 245), see sketch.

US-G10 with ST05 1/1 ... 2/1

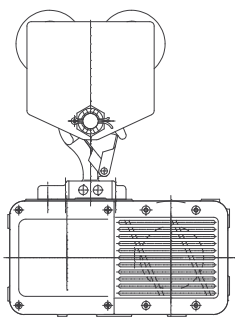

Fig. 13

US-G10 with ST10 1/1

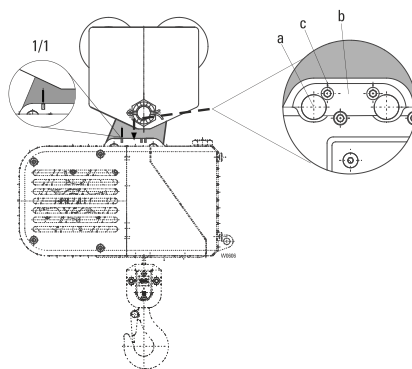

Fig. 14

KFN10/32 1/1

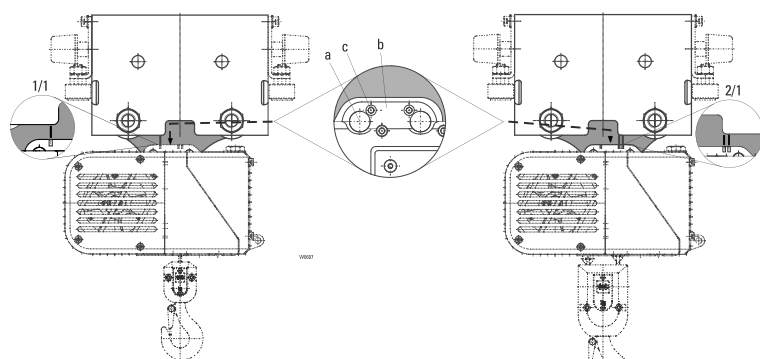
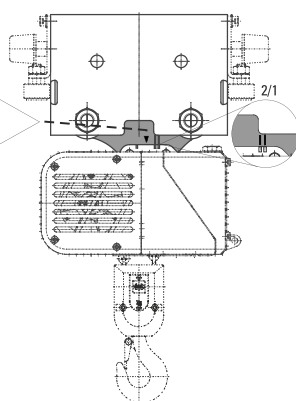

Fig. 15

KFN10/32 2/1



KFN 63 2/1

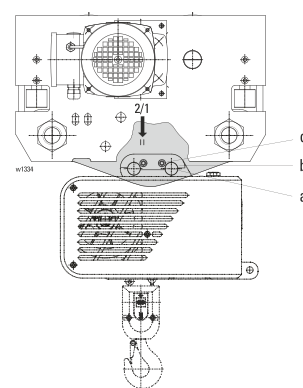

Fig. 16

2. Slide trolley onto runway or push on from below after swivelling the side cheeks up.
3. Check that screws and nuts are tightened with specified torque, see page 52.
4. Ensure screws are locked!

4 Installation

1. KFK

Fit suspension piece with suspension bolt (a) to chain hoist. Observe installation position of suspension piece for 1/1 and 2/1 reeving! Lock bolt (a) with washer (b) and cir-clip (c), see sketch.

KE-T 22

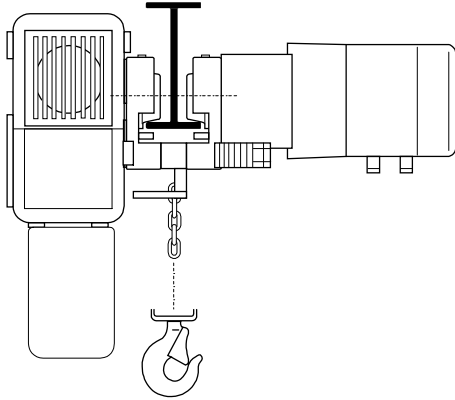

Fig. 17

KFK ..

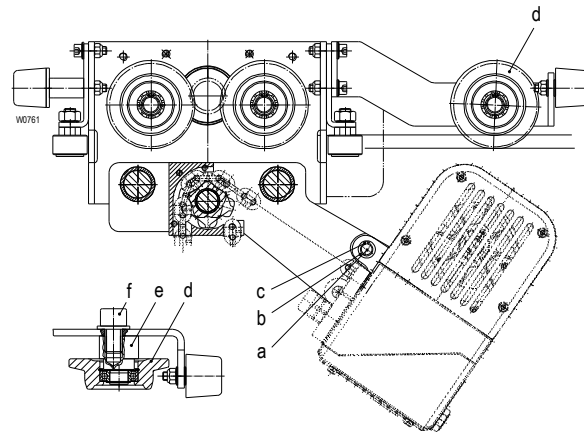

Fig. 18

Wheel Ø	Max. S.W.L. [kg]
50	500
63	500 (KE-T)
63	1000
80	3200
125	6300

2. Slide trolley onto runway or push on from below after swivelling the side cheeks up.
3. Check that screws and nuts are tightened with specified torque, see page 52.
4. Ensure screws are locked!

KFK ..

1. Turn wheel (d) by means of cam (e) until it is in contact with the running surface of the runway.
Tighten screw (f).

N.B.: The guide roller must be flush with the wheels

NOTICE

Danger of increased wear

Poor beam quality or lopsided running of the trolley may lead to increased wear. Ensure that the trolley runs smoothly over the whole distance.

4 Installation

4.4 Attach the trolley to the runway beam

- (1) Screw lock
- (2) Nut
- (5) Trolley side cheek
- a Track clearance

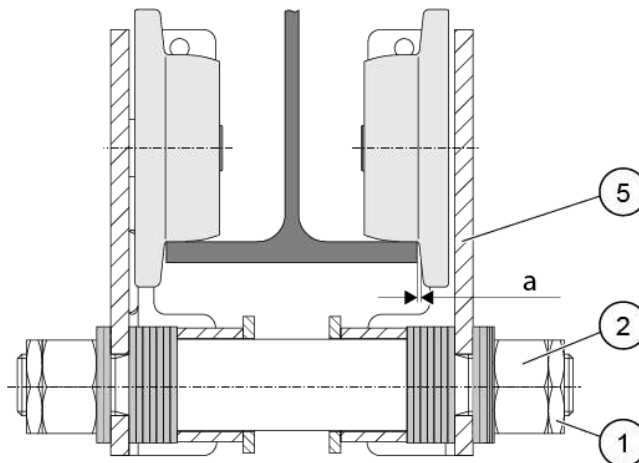

b_0486

Fig. 19

1. On one side, loosen the screw lock (1) and nut (2) and open the trolley side cheek (6) sufficiently far that the trolley fits on the runway beam.
2. Attach the trolley to the runway beam.
3. Make sure that the track clearance (a) is not greater than 3 mm on one side; if necessary readjust the trolley (see chapter Adjust trolley to runway width).
4. Tighten the nut (2) with the specified torque (see table).
5. Attach screw locks (1).

Type	Nm
US-G10	Tighten castellated nut and then release to the next cotter pin hole.
K.T 22	52
KFN 10 KFK 10	130
KFN 32 KFK 32	470
KFN 63 KFK 63	1100