

1056 - CRANE FORKS



The 1056 has been designed to give flexibility when required to move oversized and normal packs of block and bricks as well as palletised goods around site. This unit is supplied with heavy duty sprung lifting eye allowing automatic levelling of any load being carried. The unit also comes supplied with net hooks allowing the addition of a load safety net

Item Code	SWL (Kg)	Tine Length (mm)	Tine Cross Section (mm)	Height (mm)	Weight (kg)
1056.7	1000	1000	40 x 90	1500	120
1056.9	2000	1000	40 x 100	1500	198
1056.10	3000	1000	45 x 130	1700	364

Eichinger Equipment Ltd
69-73 James Road, Frimley, Camberley, GU15 2RH
T: 01276 605 970 F: 01276 682 913 E: sales@eichinger.co.uk

The following instructions must be read and understood by each intended user of this equipment; if there is anything you do not understand contact Eichinger Equipment Ltd.

Ensure the equipment is adequate for the job you need to carry out.

You must not operate this equipment if you are under the influence of alcohol, drugs or if you are feeling unwell.

A risk assessment should be carried out prior to moving or using this equipment.

The following PPE (Personal protective equipment) should be worn when using this equipment:

Gloves / Goggles / Hard Hat / Steel Toecap boots / Hi-Vis Vest

We also suggest suitable clothing should be worn.

Familiarise yourself with the equipment, its use and how it works!

As this equipment is used at multi-level, ensure the intended area for use is clear of overhead cables and power lines or similar hazards which may affect its safe use. This equipment must always be used in conjunction with your site safety policies.

The work area must be clear of obstructions with adequate space for the operative to work safely around the equipment.

Check and ensure the equipment is inspected and in a safe condition prior to its use. Also ensure that its load is stable and secure.

SETUP

Attach the lifting hook onto the lifting eye of the self leveling crane forks ensuring the hooks gate is properly closed and secure.

Adjust the width of the forks by undoing the eye bolts and sliding the forks either in or out for the intended load keeping the load central on the 1056 at all times.

Once in position tighten the eye bolts to secure the forks and stop them moving during transit.

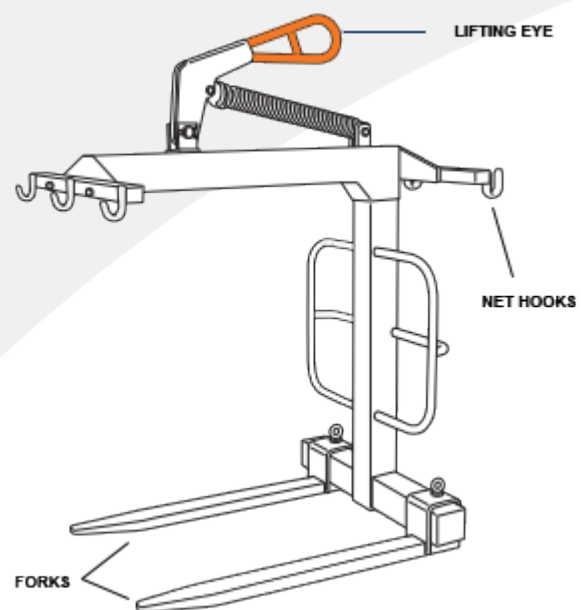

WARNING!

Do not use this equipment for dragging loads; it should be used for lifting loads clear of the ground only. Always ensure that the forks are set to the correct width for each load lifted.

REMEMBER:

To avoid the risk of injury keep hands and feet clear of the unit at all times during use. Only use safety handles to manoeuvre the unit during use and only when it is safe to do so. At no time should anyone either trained personnel or otherwise be allowed under the raised load or near enough to be at risk in the event that the load moves.



The following instructions must be read and understood by each intended user of this equipment; if there is anything you do not understand contact Eichinger Equipment Ltd.

Ensure the equipment is adequate for the job you need to carry out.

You must not operate this equipment if you are under the influence of alcohol, drugs or if you are feeling unwell.

A risk assessment should be carried out prior to moving or using this equipment.

The following PPE (Personal protective equipment) should be worn when using this equipment:

Gloves / Goggles / Hard Hat / Steel Toecap boots / Hi-Vis Vest

We also suggest suitable clothing should be worn.

Familiarise yourself with the equipment, its use and how it works!

As this equipment is used at multi-level, ensure the intended area for use is clear of overhead cables and power lines or similar hazards which may affect its safe use. This equipment must always be used in conjunction with your site safety policies.

The work area must be clear of obstructions with adequate space for the operative to work safely around the equipment.

Check and ensure the equipment is inspected and in a safe condition prior to its use. Also ensure that its load is stable and secure.

USING THE EQUIPMENT

The user of this equipment must assess the load to be lifted prior to using the 1056.

Ensuring that the load is secured to the pallet, raise the 1056 just clear of the ground and slide the forks into the pallet intended to be lifted. The pallet and its load must be no longer than the length of the forks.

Once the forks are in position raise the load clear of the ground and check that the load is balanced and central. Providing these instructions are followed the 1056 will keep the load level by the self-levelling lifting arm.

Once the load is deemed safe place the safety net under the 1056 and its load and fit it securely to the net hooks ensuring that any excess is gathered up onto next hooks. *The net should be tight to the load.

Once satisfied that the load is safe proceed to transfer the loaded unit to its intended position in a slow and controlled manner avoiding sudden movements.

Once in its intended position to be unloaded lower the 1056 until just off the ground. Remove the safety net and land the load you can now move the crane forks out and away from the pallet.

Once the unit is finished with, lower it to the ground where it will be stored. Release the lifting hook from the Lifting eye and clean the unit down ready for its next use.



THE 1056 SHOULD NEVER BE USED WITHOUT A RESTRAINT NET & THE NET MUST ALWAYS BE PULLED TIGHT AROUND THE LOAD. THE NET SHOULD NOT BE USED FOR ANY OTHER APPLICATION.

THE NET IS NOT DESIGNED TO CATCH A FALLING LOAD.

