

## PTAT1.5 Terrain Pallet Parts Breakdown

Product Code: PTAT1.5

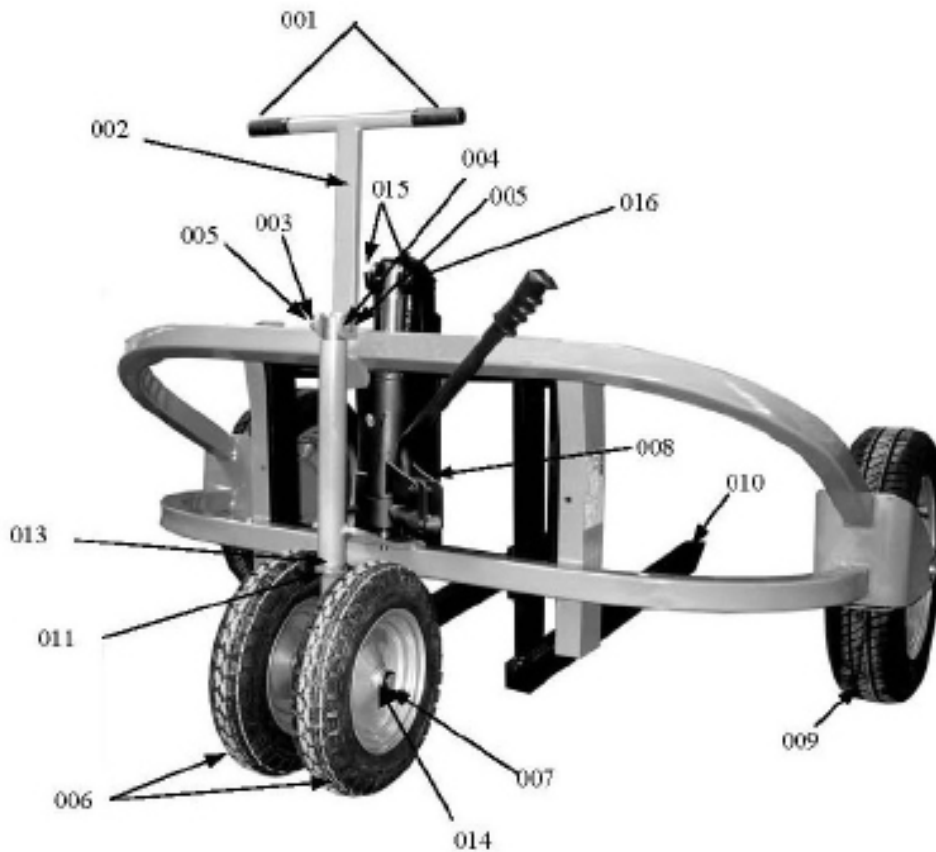

Part No.	PTAT1.5 Quantity	Part Name
001	2	Grip Ref. 3504.22
002	1	Handle
003	1	M12 Safety Nut
004	1	M12 Bolt x 65
005	2	Washer A8
006	2	Small Wheels
007	2	Circlip
008	1	Hydraulic Cylinder

Part No.	PTAT1.5 Quantity	Part Name
009	2	Large Wheel
010	1	Fork
011	1	Small Wheel Cross-Axle
012	1	Discontinued
013	2	Grease Nipple
014	2	Grease Nipple
015	2	Flanged Pin 3 x 30
016	1	Cylinder Support

## PTAT1.5 Terrain Pallet Parts Breakdown

Product Code: PTAT1.5

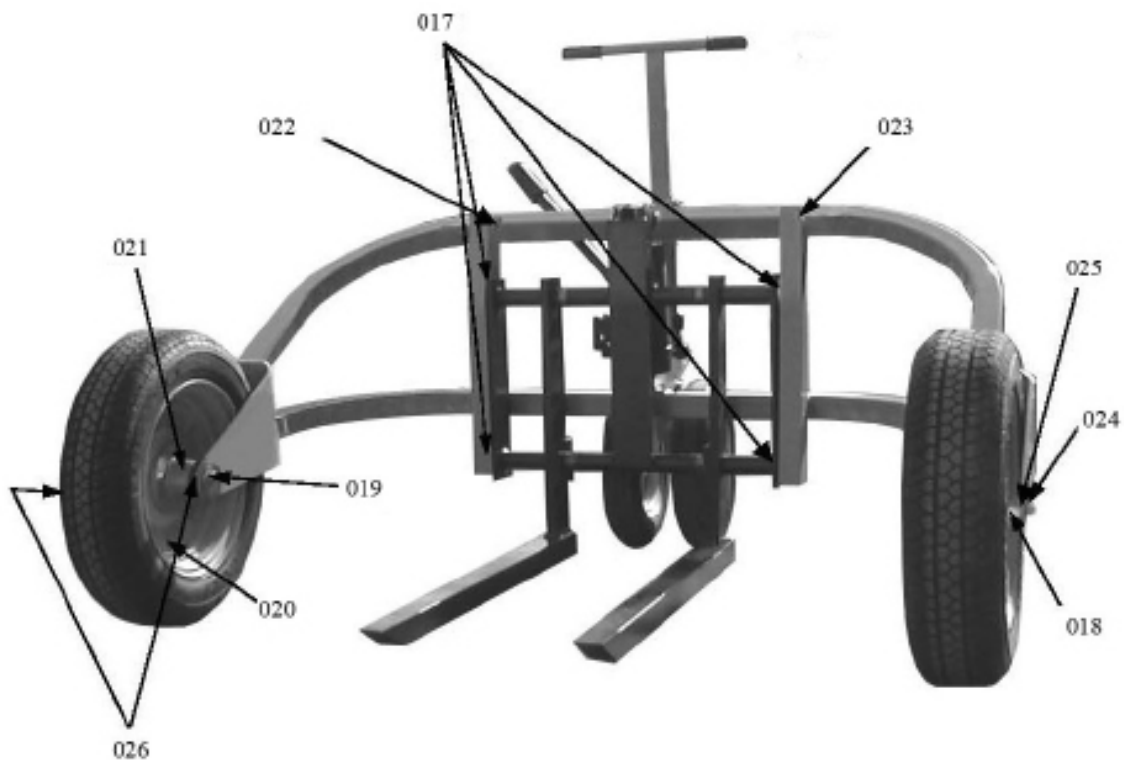

Part No.	PTAT1.5 Quantity	Part Name
017	4	Sheave Guide
018	4	Distance Tube
019	2	Large Wheel Axle
020	8	Conical Wheel Bolt
021	2	Large Wheel

Part No.	PTAT1.5 Quantity	Part Name
022	2	M 8 x 15 Screw
023	2	M 8 Nut
024	4	M 16 Nut
025	4	17 Washer
026	4	6204 2RS Bearings